

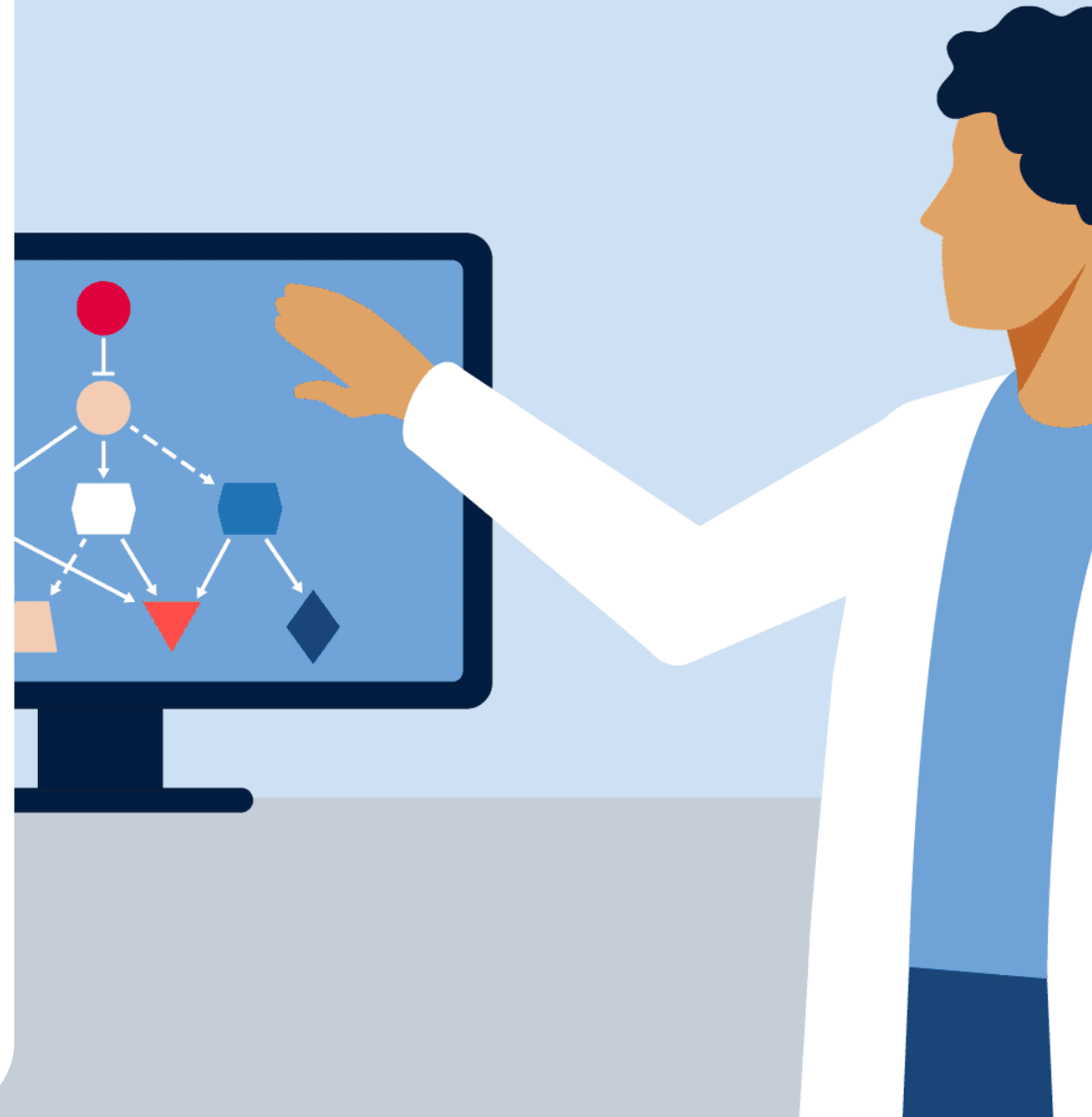

QIAGEN Ingenuity Pathway Analysis

Kyle Nilson, PhD
kyle.nilson@qiagen.com

Field Software Trainer
QIAGEN Digital Insights



Legal disclaimer



The QIAGEN products shown here are intended for molecular biology applications. These products are not intended for the diagnosis, prevention or treatment of a disease.

For up-to-date licensing information and product-specific disclaimers, see the respective QIAGEN kit instructions for use or user operator manual. QIAGEN instructions for use and user manuals are available at www.qiagen.com or can be requested from QIAGEN Technical Services (or your local distributor).

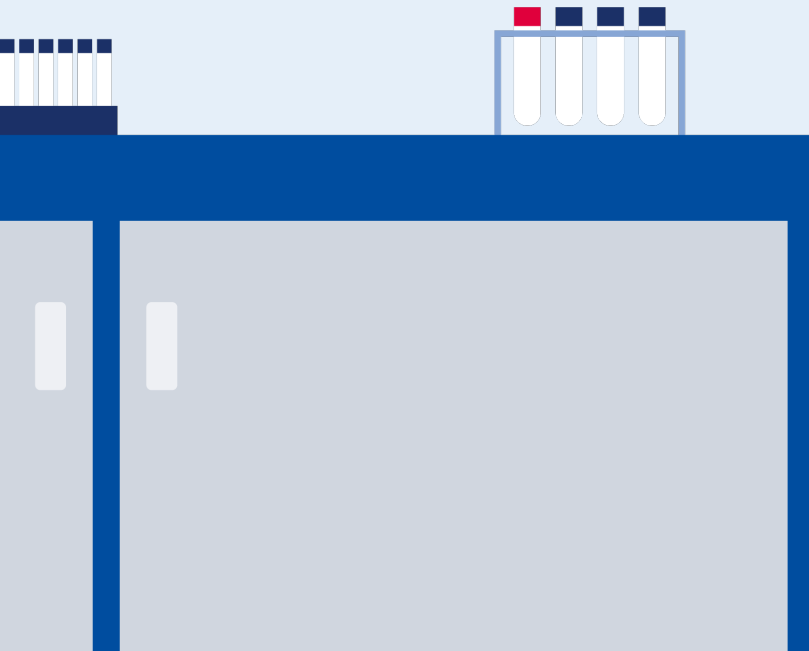

Remember, training and support are included with your license



ts-bioinformatics@qiagen.com

Technical and Scientific Support

kyle.nilson@qiagen.com

Field Software Trainer

brittany.kilb@qiagen.com

Senior Account Manager

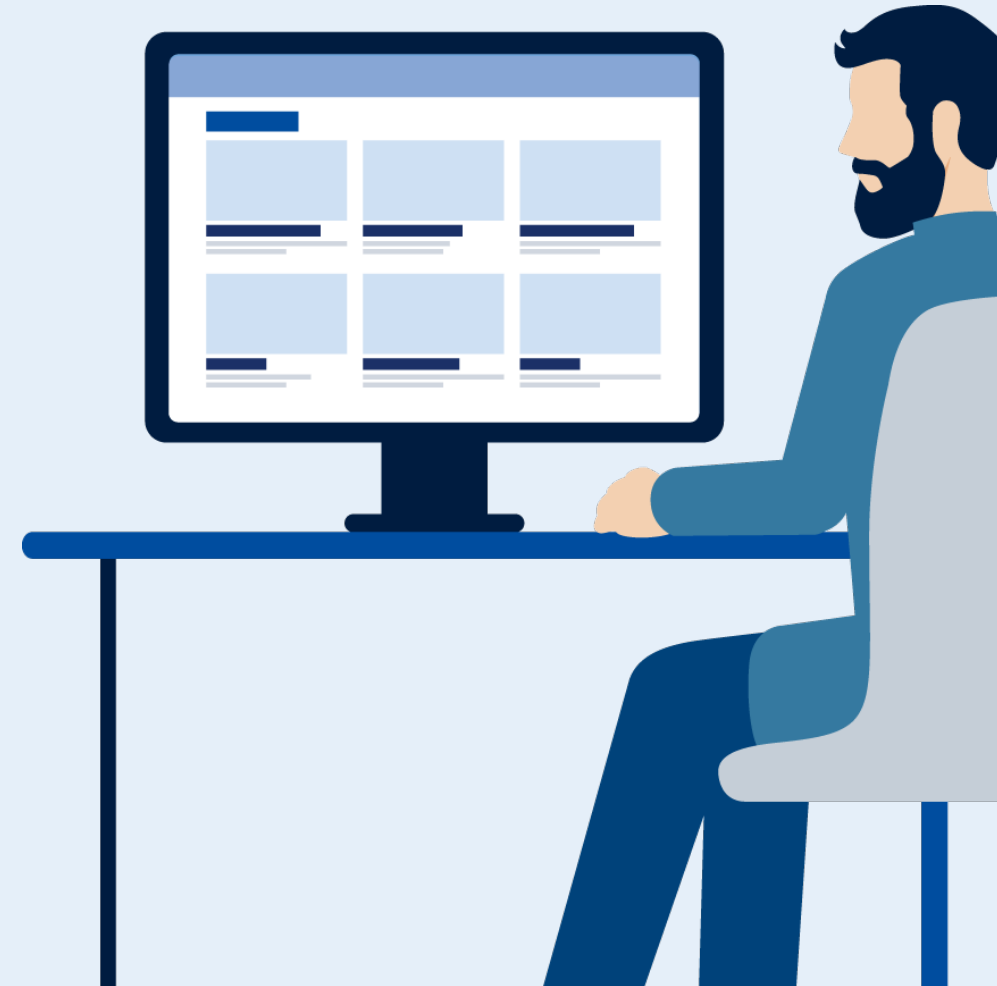

Interpret your data and highlight pathways driving biological impact



Intrapersonal skin biopsies



lesional
[n = 57]

vs.



non-lesional
[n = 54]

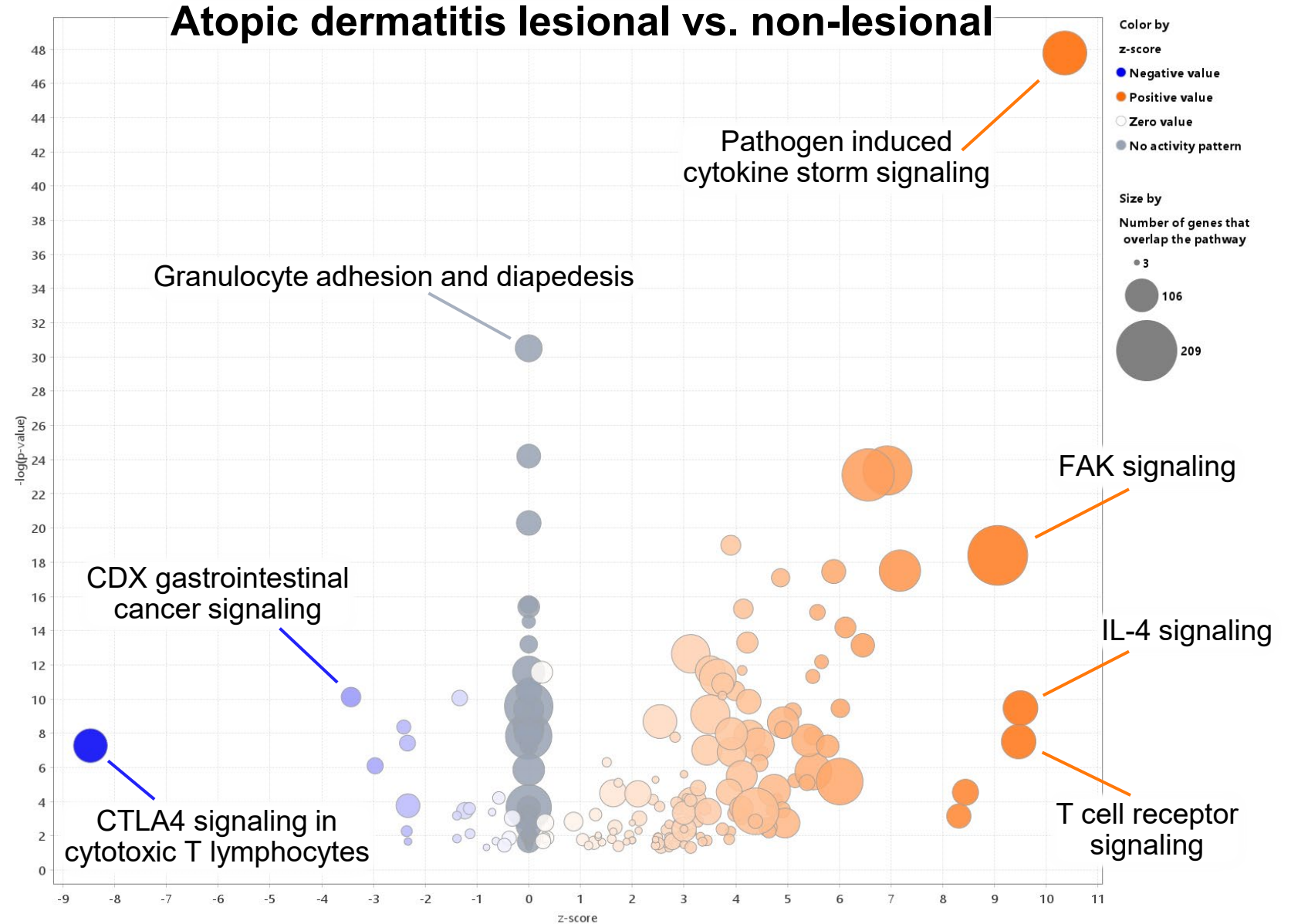

What kinds of questions can you answer without your own data?

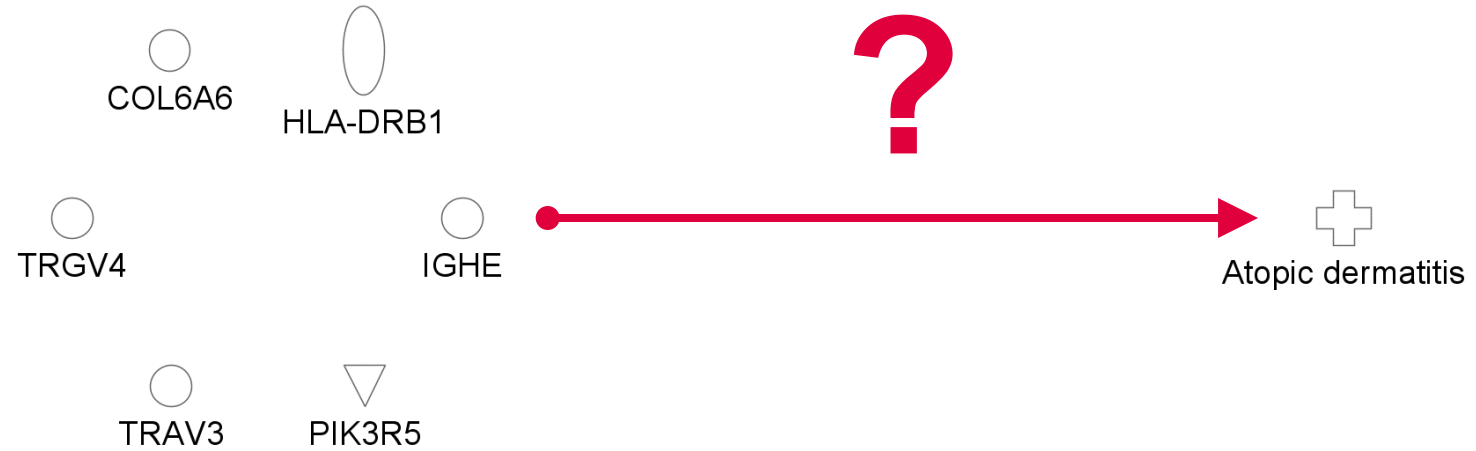

Build networks from scratch and discover potential drug targets

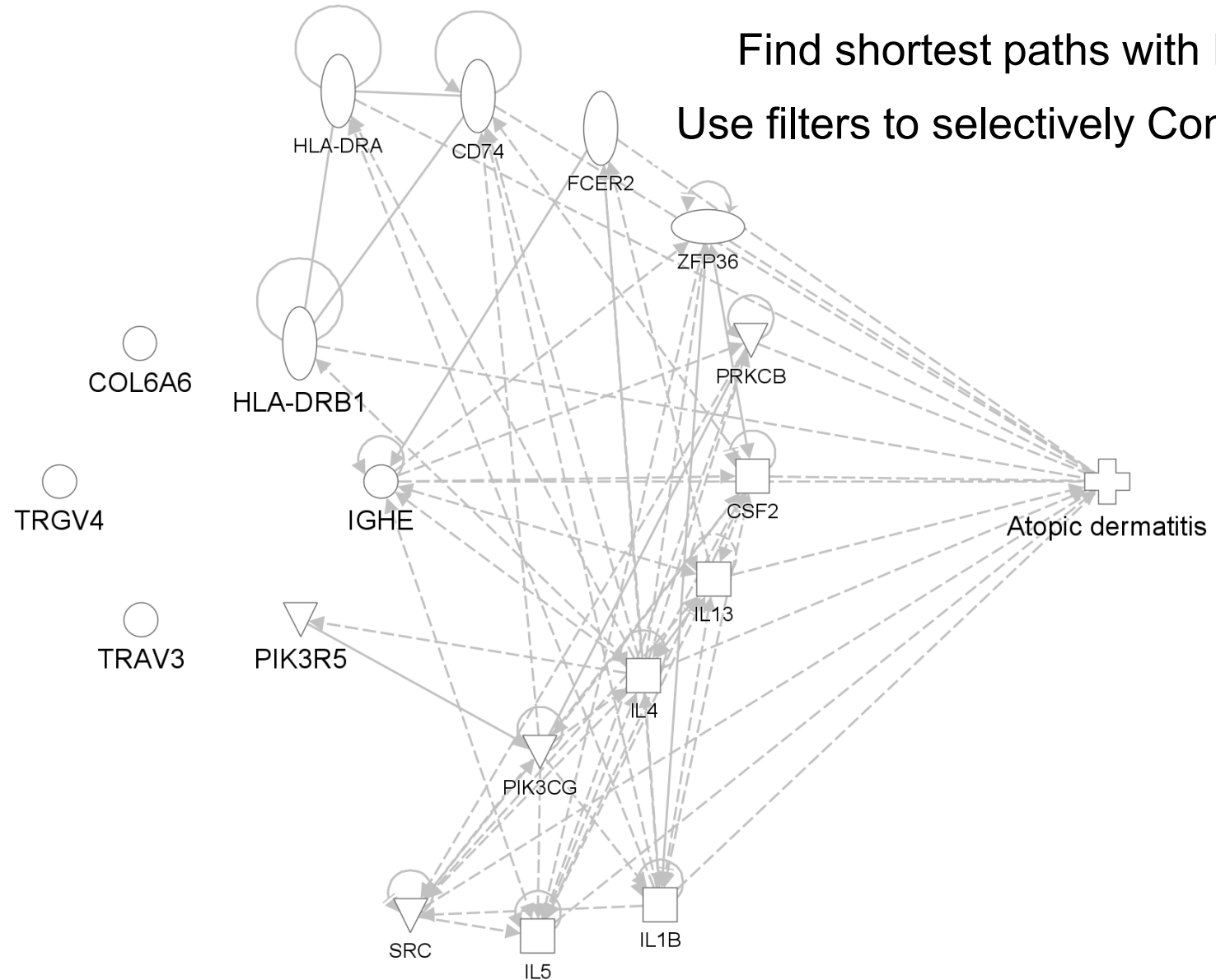

Build networks from scratch and discover potential drug targets

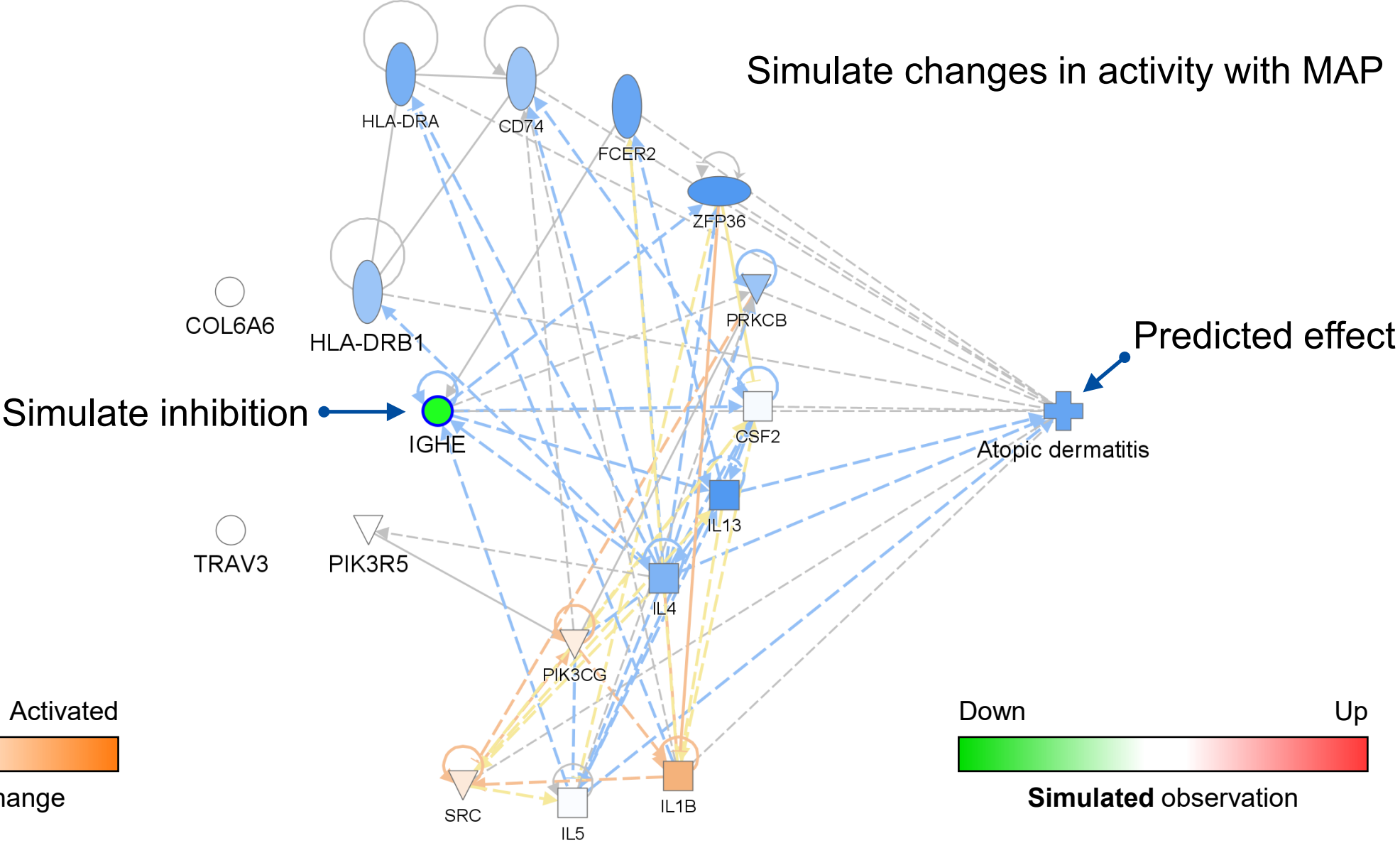

Build networks from scratch and discover potential drug targets

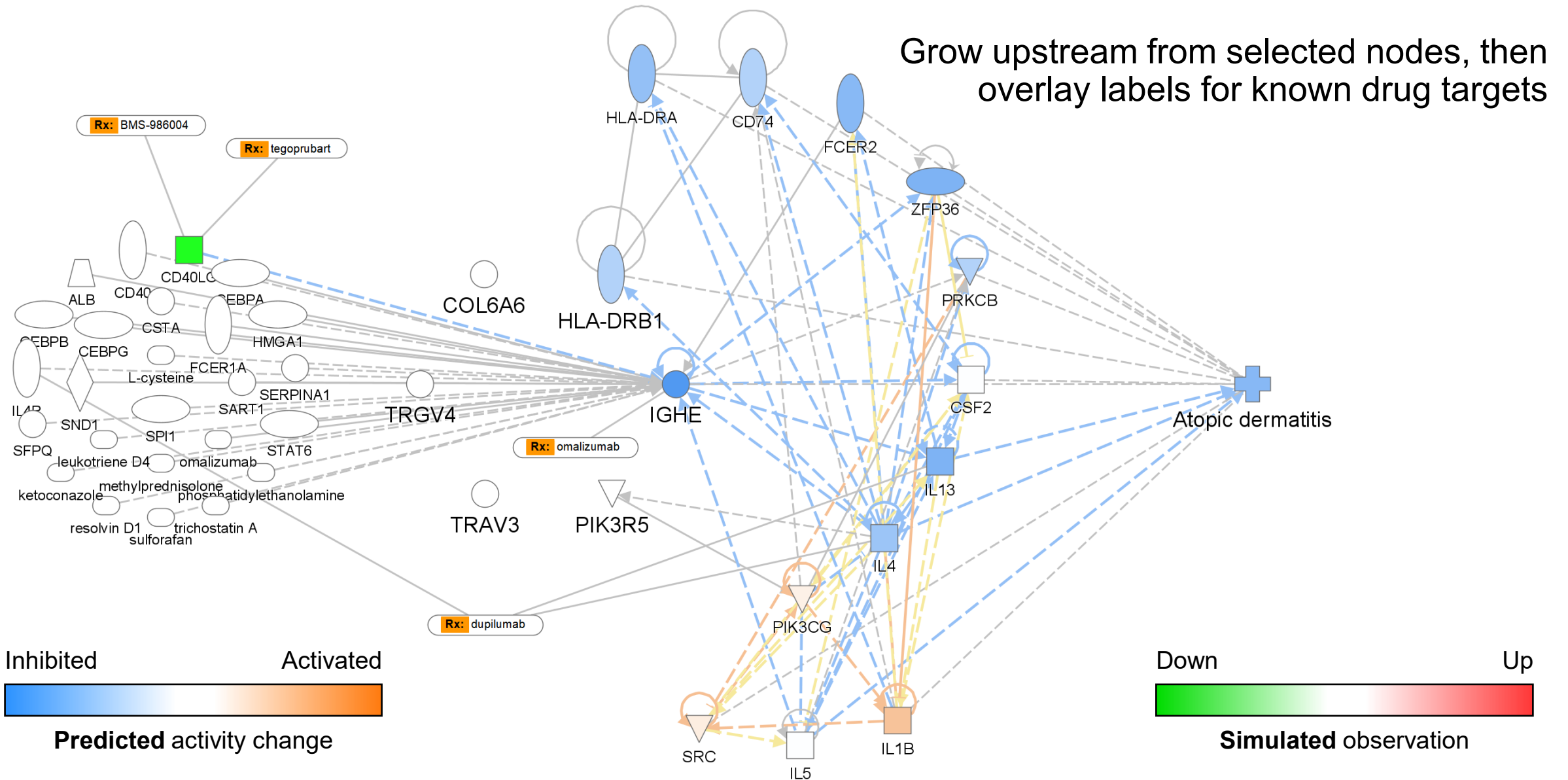

BMS-986004 could be a potential candidate for atopic dermatitis

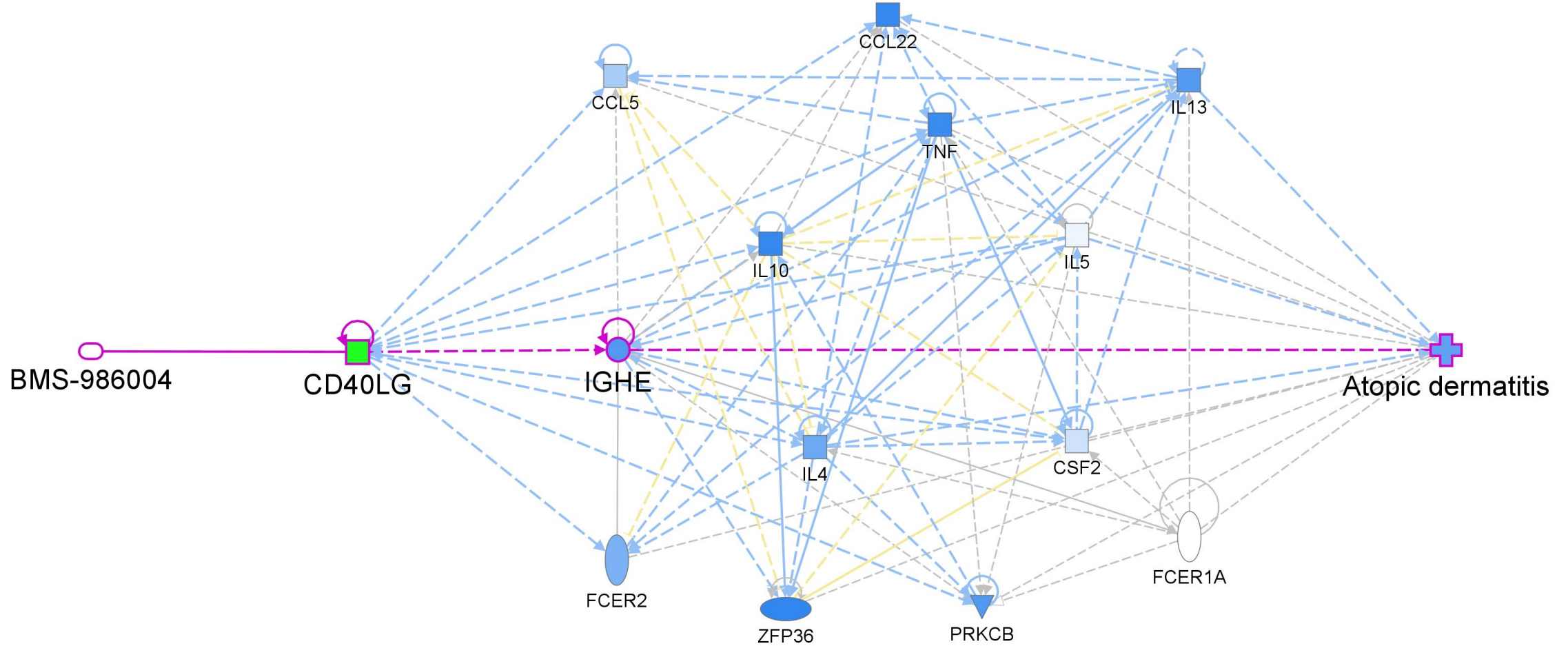

Indication	FDA Approval Status	Trial Status	Clinical Trial Sponsor(s)	NCT#	Last Updated
immune thrombocytopenic purpura	Phase 1/Phase 2	Completed	Bristol-Myers Squibb	NCT02273960	2019-07-15
acute graft-vs-host disease	Phase 1	Recruiting	H. Lee Moffitt Cancer Center and Research Institute	NCT03605927	2022-12-30
acute graft-vs-host disease	Phase 1	Recruiting	H. Lee Moffitt Cancer Center and Research Institute	NCT03605927	2022-12-30

Agenda

Perform pathway analysis on your own 'omics data

Compare and contextualize your results with other studies

Build networks from scratch and explore relationships

Options to tackle differential expression before using IPA



Ingenuity Pathway Analysis is powered by manually-curated findings



Up-to-date relationships

Weekly top-tier journal updates
Quarterly for clinical databases

14+ million findings

Manually curated using
controlled vocabulary

Decades of knowledge

Over twenty years of curated data
mapped into directional networks

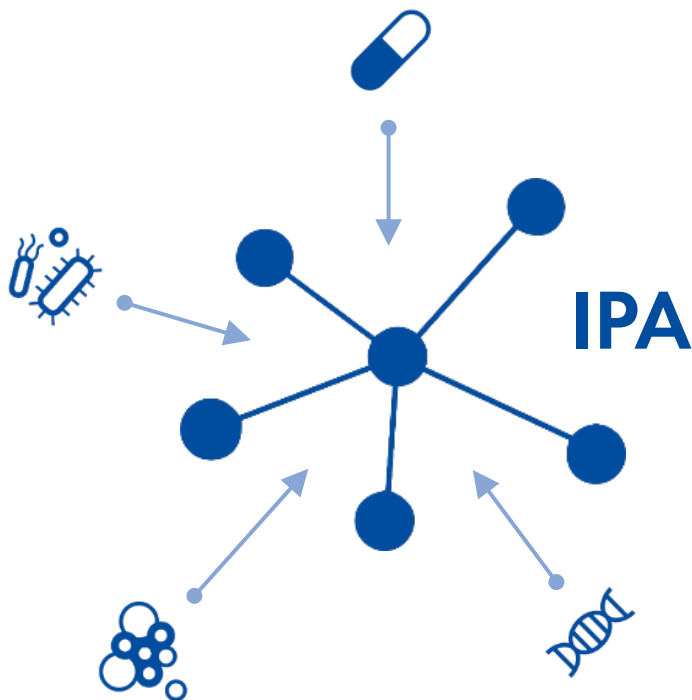

EGF – EGFR

[one of many]

Type: **activation**
Direction: **directional**
Effect: **increases**
Directness: **direct**
Tissue: **epithelial cells**
Location: **plasma membrane**
Source: **PMID: 17909010**

cetuximab – EGFR

[one of many]

Type: **phosphorylation**
Direction: **directional**
Effect: **decreases**
Cell line: **CaR1 cells**
Organism: **human**
Experiment: **immunoblot**
Source: **PMID: 23213241**

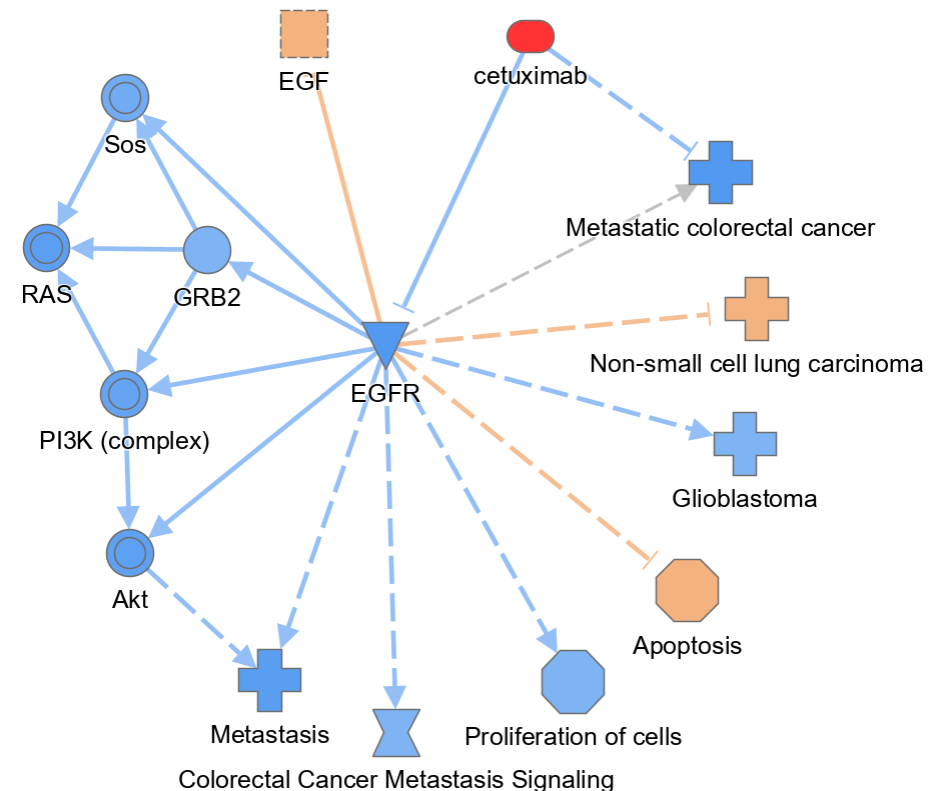

Curated research findings are stored as relationships and nodes

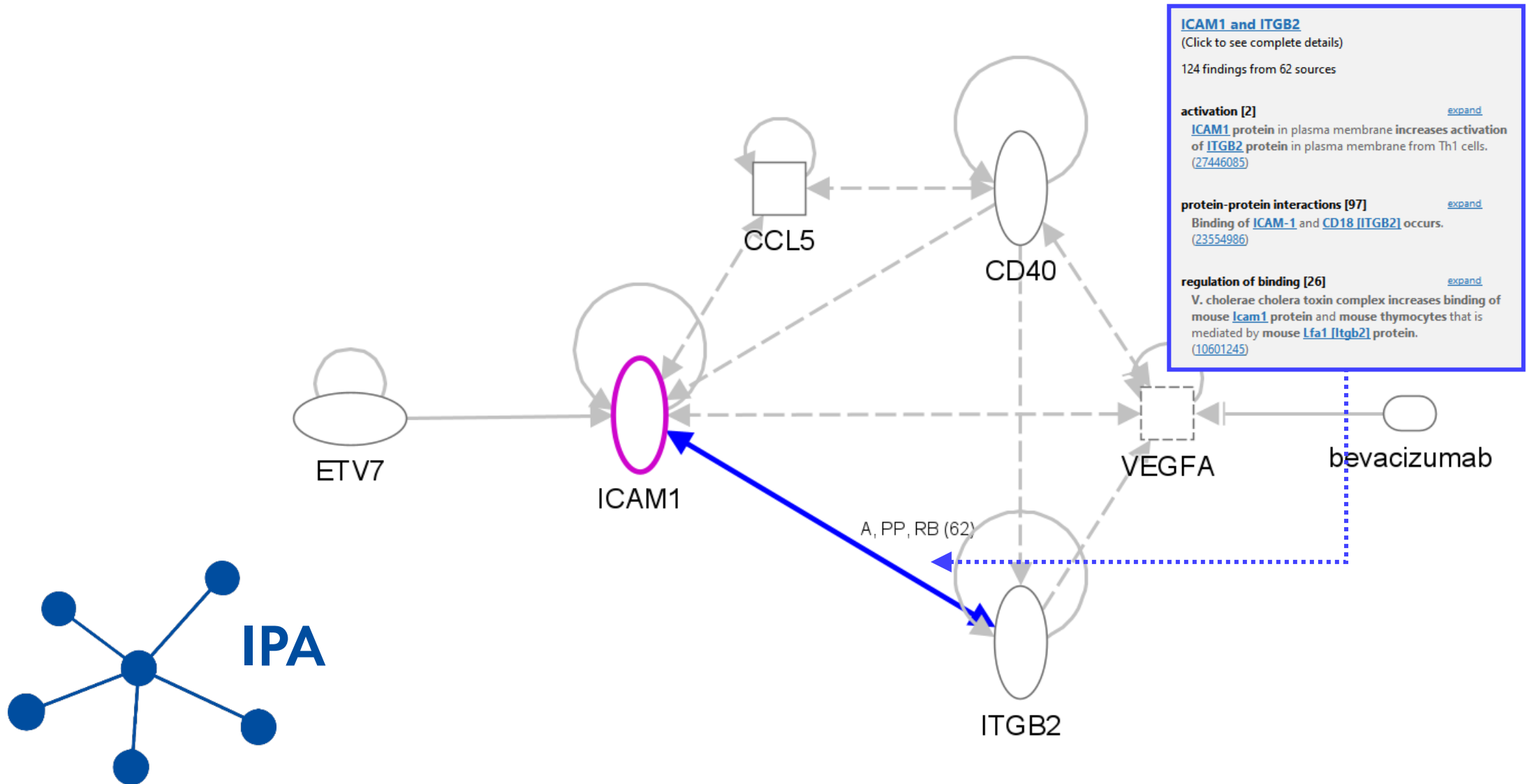

Simulate activity and predict change using directional knowledge

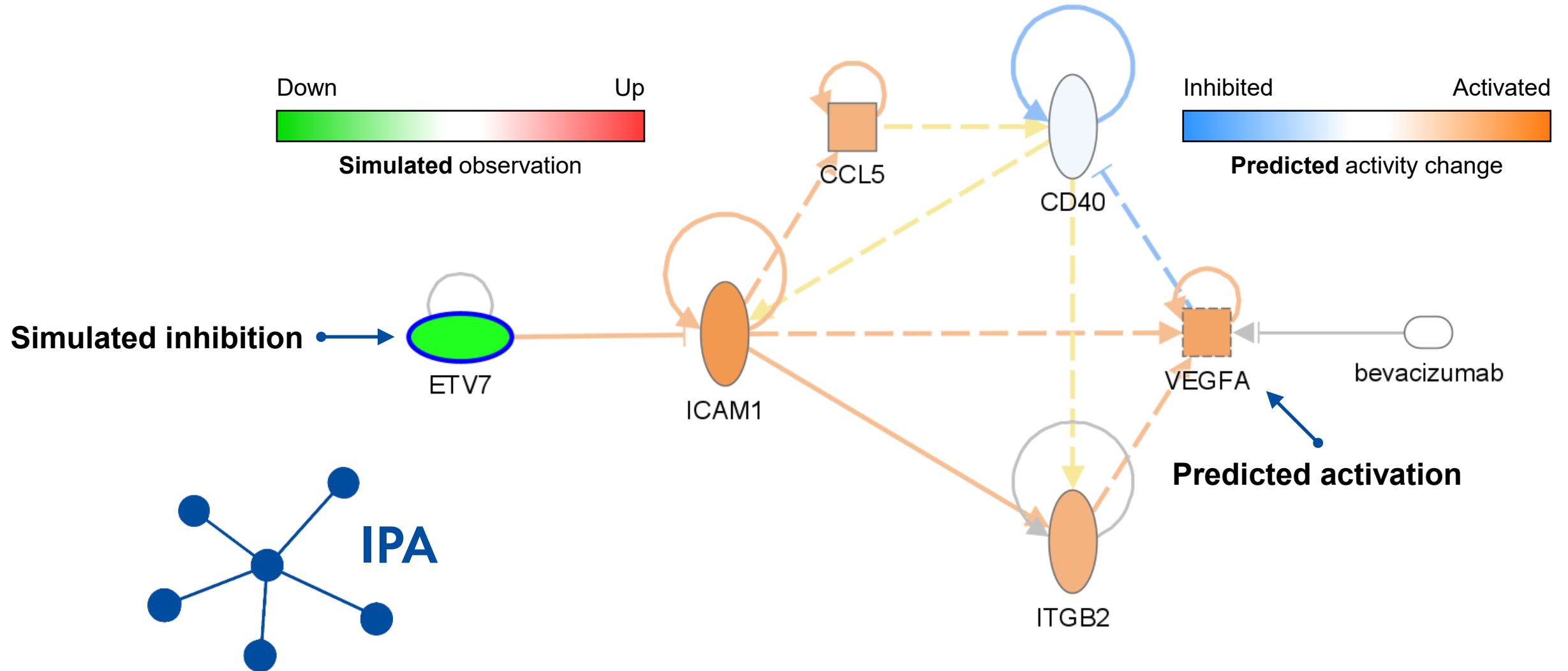

Ingenuity Pathway Analysis uses case vs. control DEGs as input

This can be a simple list with arbitrary values

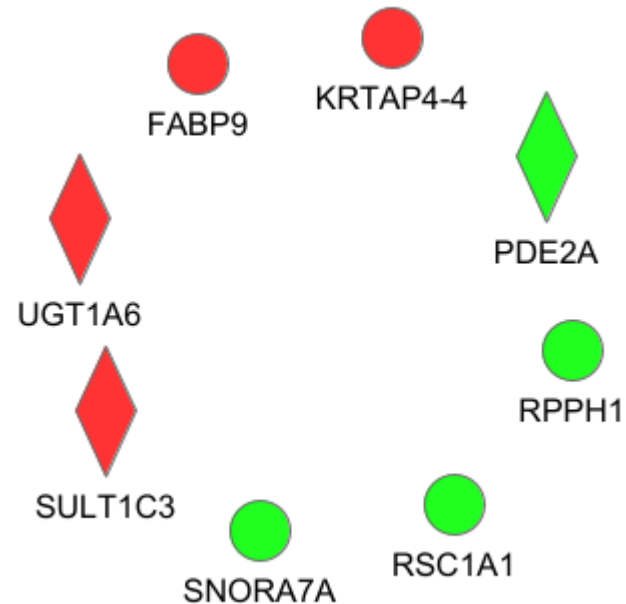

Gene	Change
FABP9	2
KRTAP4-4	2
SULT1C3	2
UGT1A6	2
PDE2A	-2
RPPH1	-2
RSC1A1	-2
SNORA7A	-2

Ingenuity Pathway Analysis uses case vs. control DEGs as input



This can be a differential expression table with ratios, fold changes, or log2FCs

IDs (required)

Ratio, fold change, etc.

Significance (optional)

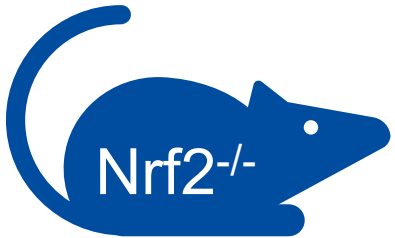

Knockout vs. wild type

	Transcript IDs	Ratio KO vs WT	p-value KO vs WT	Adj p-value KO vs WT
1				
2	NM_008866	1.02453	0.805551	0.971466808
3	NM_001159751	0.952735	0.184285	0.736421598
4	NM_133826	0.95185	0.279682	0.798486361
5	NM_001204371	0.92321	0.215736	0.758991902
6	ENSMUST00000027040	1.01667	0.795501	0.96971034
7	NM_001195732	1.00906	0.910633	0.987645184
8	NR_045188	0.990928	0.869495	0.981378292
9	NM_183028	0.921393	0.256484	0.784821849
10	NM_021511	0.932214	0.34333	0.831316277
11	ENSMUST00000144177	0.954012	0.45081	0.875692461
12	BC066997	1.04638	0.469901	0.882652167
13	NR_040462	0.881149	0.0974207	0.644692854
14	NM_133220	1.12049	0.0580533	0.57002282
15	NM_177722	1.02386	0.624477	0.932387654
16	NM_026493	0.990948	0.857147	0.97936759
17	NM_029525	0.873437	0.0734839	0.602439682
18	NM_001160369	1.01077	0.862964	0.980443879
19	NR_045297	0.980747	0.734801	0.957595072
20	NM_001198565	1.07234	0.413319	0.8723899

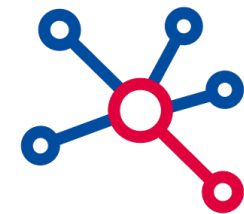

Core analysis results

IPA uses your input to calculate enrichment and predicted activity

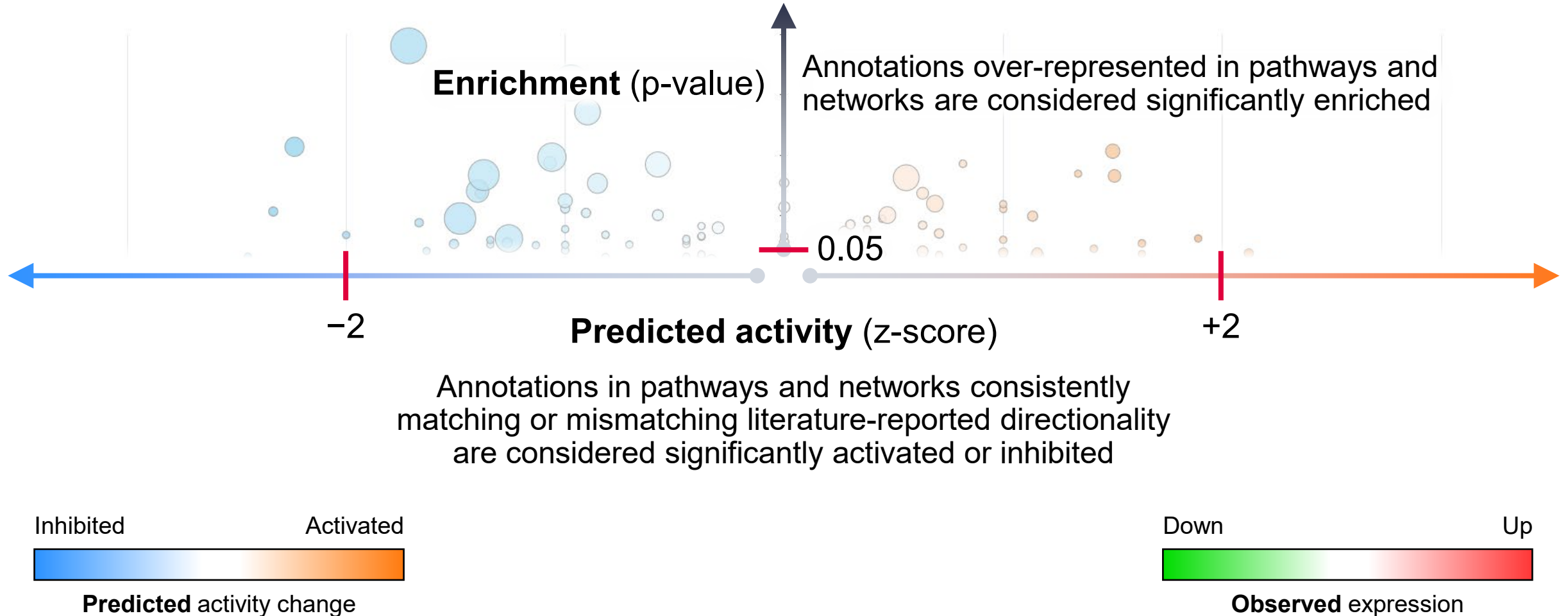

IPA calculates enrichment and predicted activity for these entities

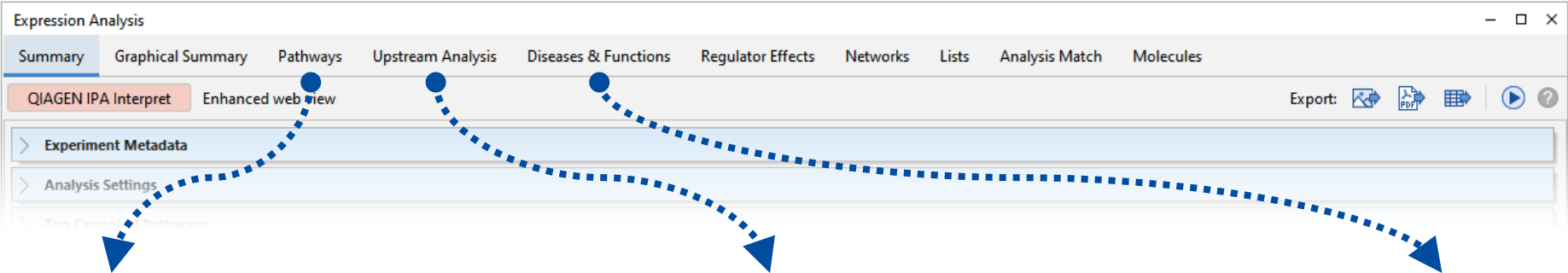

Canonical pathways

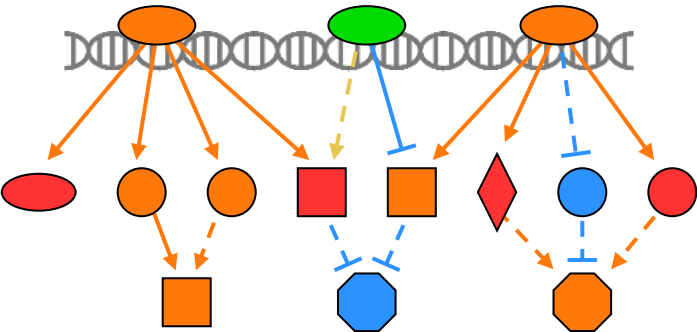

Upstream regulators

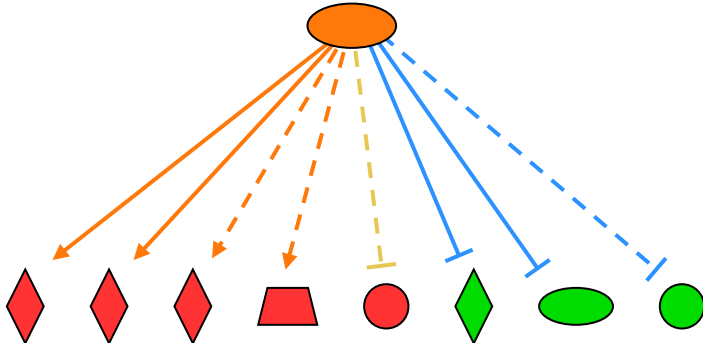

Downstream effects

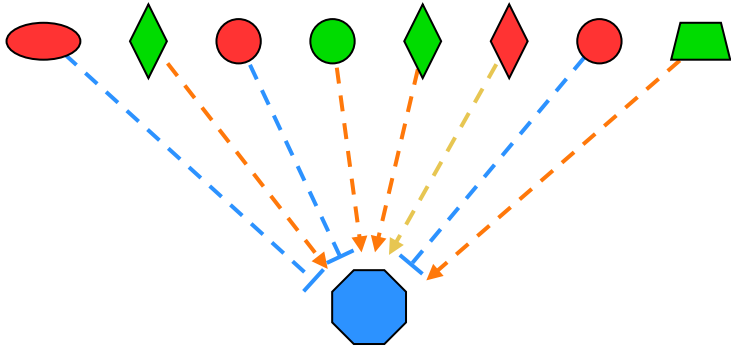

Inhibited Activated

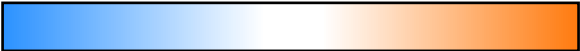

Predicted activity change

Down Up



Observed expression

Agenda

Perform pathway analysis on your own 'omics data

Compare and contextualize your results with other studies

Build networks from scratch and explore relationships

Options to tackle differential expression before using IPA



Perform pathway analysis on your own 'omics data

Quickly upload, analyze, and share your IPA results

- Data upload, analysis setup, and selecting cutoffs
- Share with IPA Interpret, an online overview of your results

Dive deep into the biology behind your observed changes

- Prioritize and interpret changes in Canonical Pathways
- Identify upstream regulators potentially influencing your DEGs
- Look at potential downstream effects and functional consequences

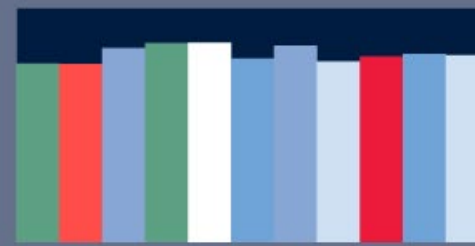

Navigating your core analysis results

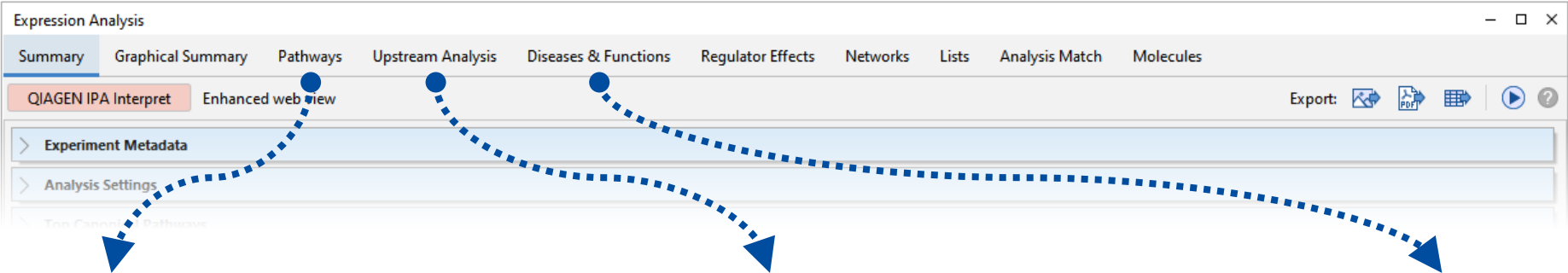

Canonical pathways

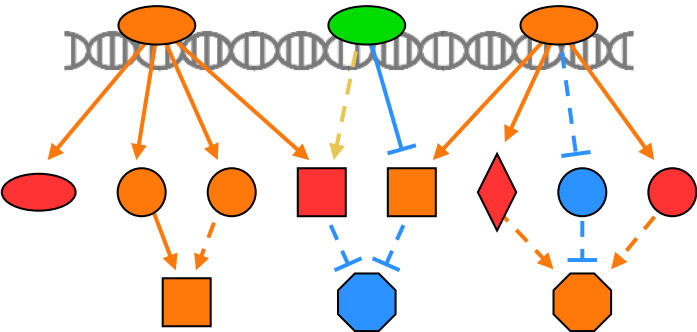

Inhibited Activated

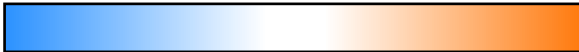

Predicted activity change

Upstream regulators

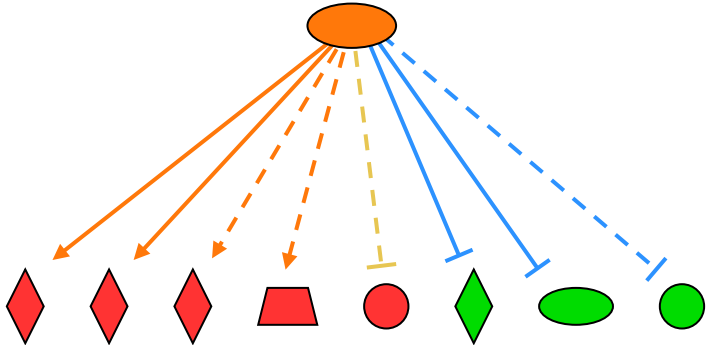

Downstream effects

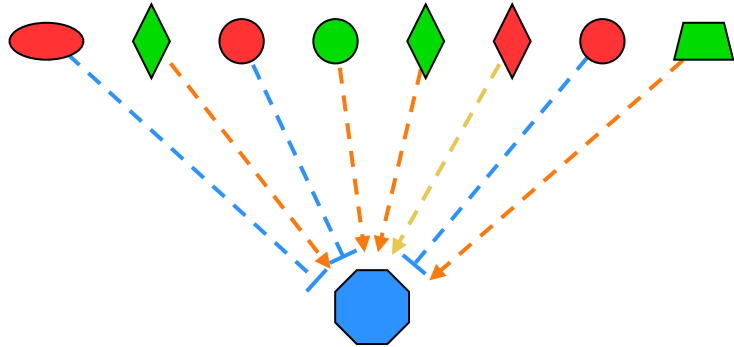

Down Up

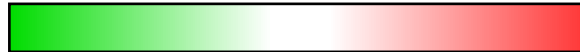

Observed expression

IPA Interpret results can be found in the Summary tab



Expression Analysis

Summary Graphical Summary Pathways Upstream Analysis Diseases & Functions Regulator Effects Networks Lists Analysis Match Molecules

QIAGEN IPA Interpret Enhanced web view

Export:

Experiment Metadata



Lesional vs Non-Lesional (Atopic Dermatitis)

Created on June 18, 2025, from observation "Lesional vs Non-Lesional (Atopic Dermatitis)" in dataset IPA_Training_Atopic_Dermatitis_Dataset

Dataset ⓘ

2634 genes passed cutoffs (872 down and 1762 up)

Cutoffs: Expr Fold Change <-1.7, >1.7, Expr p-value <0.05

X Axis: Expr Fold Change Y Axis: Expr p-value

● Down-regulated ● Up-regulated ● Not analysis-ready

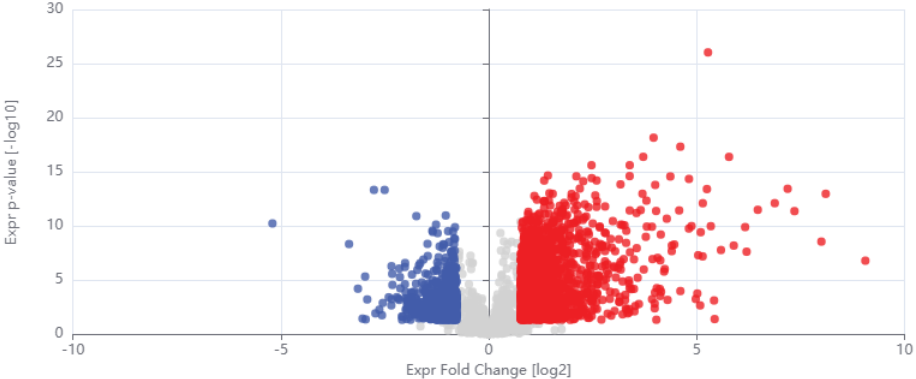

Graphical Summary

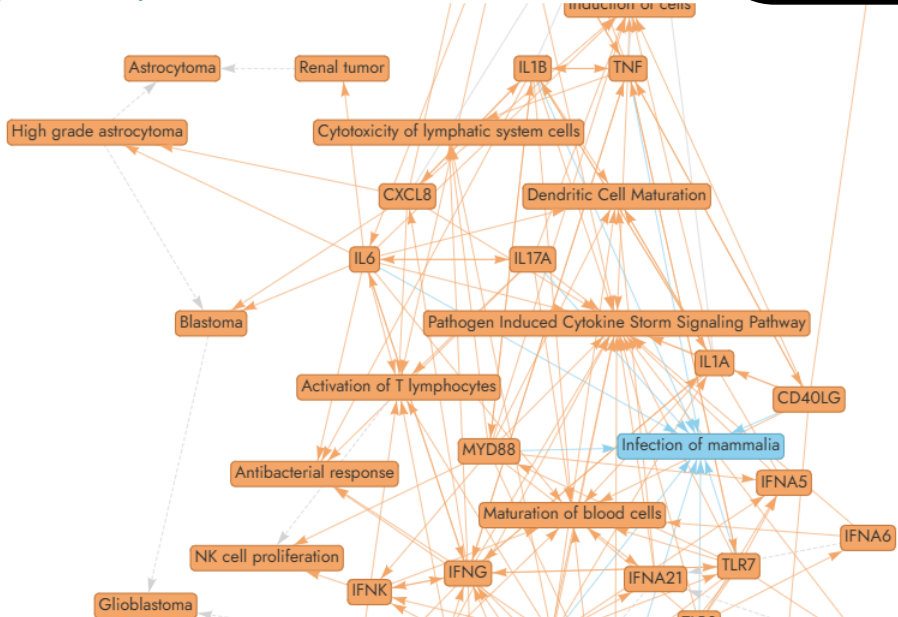

To share, add your results to a shared project, then copy the link



The screenshot shows the IPA software interface with the 'Share Manager' dialog box open. The 'Share' menu is highlighted, and a mouse cursor points to 'Share Manager...'. The dialog box contains instructions on how to share files, a 'New Shared Project' button, a dropdown menu for 'Choose Shared Project to Edit' (set to 'QIAGEN FAS Team'), a list of 'Shared Files', and a table of 'Shared Project Members'.

Shared Files

- Ulcerative Colitis (GSE73661) - 2025-03-05
- Lesional vs Non-Lesional (Atopic Dermatitis)
- GSE165252 Responder vs. Non-Responder (atezolizumab)

Shared Project Members

Members	Status
devendra.mistry@qiagen.com	Pending
shawn.prince@qiagen.com	ACCEPTED

Disease vs. normal: lesional vs. non-lesional atopic dermatitis

Viewing and exporting results from IPA Interpret



IPA Interpret | Canonical Pathways

analysis.ingenuity.com/ipw/RVy_DS08o_2CDODA-BNBIg/canonical-pathways/table

QIAGEN IPA Interpret

Want to analyze your own data? Kyle Nilson Logout

Lesional vs Non-Lesional (Atopic Dermatitis) / Canonical Pathways

Canonical Pathways

Signaling and metabolic pathways that are potentially activated or inhibited

Table Bar Chart Bubble Chart

Showing all 1018 canonical pathways

Pathway	P-value ▲	BH P-value	Activation z-score ⓘ	Percentage overlap	Overlapping molecules	Total pathway size
Immunoregulatory interactions between a Lymphoid and a non-Lymphoid cell	1.18e-64	1.20e-61	10.25	50.23%	108	215
Pathogen Induced Cytokine Storm Signaling Pathway	8.47e-42	4.31e-39	8.66	30.37%	116	382
Granulocyte Adhesion and Diapedesis	4.09e-39	1.39e-36	--	39.71%	81	204
Cell surface interactions at the vascular wall	1.13e-28	2.87e-26	7.48	33.18%	71	214
Th1 and Th2 Activation Pathway	1.07e-27	2.18e-25	--	35.80%	63	176
Agranulocyte Adhesion and Diapedesis	1.66e-26	2.50e-24	--	31.25%	70	224

Pathway representation

Immunoregulatory interactions between a Lymphoid and a non-Lymphoid cell [Figure Legend](#) OFF

↓ Immunoregulatory interactions between a Lymphoid and a non-Lymphoid cell

A number of receptors and cell adhesion molecules play a key role in modifying the response of cells of lymphoid origin (such as B-, T- and NK cells) to self and tumor antigens, as well as to pathogenic

Powered by QIAGEN Digital Insights © 2025 All Rights Reserved

QIAGEN IPA® Interpret is for molecular biology research use only and not intended for the diagnosis, prevention, or treatment of disease. Use of this content, analyses and / or results herein are subject to the QIAGEN Digital Insights User Agreement <https://www.qiagen.com/us/knowledge-and-support/ordering-support/bioinformatics-tc>

[Privacy Policy](#) [Trademarks & Disclaimers](#) [Terms & Conditions](#)

Click the download icon to export tabular results

Viewing and exporting results from IPA Interpret



IPA Interpret | Canonical Pathways

analysis.ingenuity.com/ipw/RVy_DS08o_2CDODA-BNBig/canonical-pathways/bubblechart

QIAGEN IPA Interpret

Want to analyze your own data? Kyle Nilson Logout

Lesional vs Non-Lesional (Atopic Dermatitis) / Canonical Pathways

Canonical Pathways

Signaling and metabolic pathways that are potentially activated or inhibited in the dataset

Table Bar Chart **Bubble Chart**

Chart Type: Bubble chart X-axis: $-\log[P\text{-value}]$ Y-axis: Pathway category

Z-Score: Positive Negative Zero Neutral or No Prediction

Figure Legend ON

Overlapping molecules 46 91 181

Pathway category	$-\log[P\text{-value}]$	Z-Score	Overlapping molecules
Immune System	~65	Positive	46
Disease-Specific Pathways	~42	Positive	91
Cellular Immune Response	~38	Neutral or No Prediction	181
Hemostasis	~28	Positive	46
Pathogen-Influenced Signaling	~25	Positive	91
Humoral Immune Response	~22	Positive	181
Cytokine Signaling	~20	Positive	46
Signal Transduction	~18	Positive	91
Cellular Growth, Proliferation and Development	~25	Negative	181
Vesicle-mediated transport	~22	Positive	46
Cancer	~20	Positive	91
Cellular Stress and Injury	~18	Positive	181
Organismal Growth and Development	~15	Positive	46

Powered by QIAGEN Digital Insights

QIAGEN IPA® Interpret is for molecular biology research use only and not intended for the diagnosis, prevention, or treatment of disease. Use of this content, analyses and / or results herein are subject to the QIAGEN Digital Insights User Agreement <https://www.qiagen.com/us/knowledge-and-support/ordering-support/bioinformatics-tc>

Privacy Policy Trademarks & Disclaimers Terms & Conditions

Viewing and exporting results from IPA Interpret



IPA Interpret | Canonical Pathways

analysis.ingenuity.com/ipw/RVy_DS08o_2CDODA-BNBIg/canonical-pathways/barchart

QIAGEN IPA Interpret

Want to analyze your own data? Kyle Nilson Logout

Lesional vs Non-Lesional (Atopic Dermatitis) / Canonical Pathways

Canonical Pathways

Signaling and metabolic pathways that are potentially activated or inhibited in the dataset

Table | **Bar Chart** | Bubble Chart

X-axis: -log[P-value] | Sort by: -log[P-value]

Z-Score: Positive (orange), Negative (blue), Zero (white), Neutral or No Prediction (grey)

Data display: Active Filters: P-Value, Z-Score | More filters

-log [P-value] display range: 2 to 63.93 | Pathways available: 1018

Positive z-score: 2 to 10.25 | Number of pathways displayed: 313

Negative z-score: -8.11 to -2.00 | Number of pathways displayed: 14

Figure Legend ON

Number next to the bar: -log[P-value]

Pathway	-log[P-value]
Immunoregulatory interactions between a Lymphoid and a Hematopoietic Organ	63.93
Pathogen Induced Cytokine Storm	41.07
Granulocyte Adhesion	38.39
Cell surface interactions	27.15
Th1 and Th2	10.25
Agranulocyte Adhesion	7.78
Class A/1 (Rhodopsin)	7.76
Dendritic Cell	7.76
Binding and Uptake of Ligands by S	7.76
Altered T Cell and B Cell Signaling	7.76

Powered by QIAGEN Digital Insights

QIAGEN IPA® Interpret is for molecular biology research use only and not intended for the diagnosis, prevention, or treatment of disease. Use of this content, and the QIAGEN Digital Insights User Agreement <https://www.qiagen.com/us/knowledge-and-support/ordering-support/bioinformatics-tc>

Use drop-down menus to filter data

Viewing and exporting results from IPA Interpret



The screenshot displays the QIAGEN IPA Interpret web interface. The main content area shows a bar chart titled 'Canonical Pathways' with the subtitle 'Signaling and metabolic pathways that are potentially activated or inhibited in the dataset'. The chart is sorted by $-\log[P\text{-value}]$ and displays 15 pathways. A 'More filters' button is highlighted with a mouse cursor, and a dialog box is open, showing a search list of pathways with checkboxes for selection. The dialog box is titled 'Canonical Pathways Display' and includes a search list with the following items:

- Ingenuity Canonical Pathways (1386) Expand all Collapse all
- Metabolic Pathways (125)
- Reactome Pathways (411)
- Signaling Pathways (848)
- Apoptosis (33)
- Cancer (59)
- Cardiovascular Signaling (29)
- Cell Cycle Regulation (19)
- Cellular Growth, Proliferation and Development (88)
- Cellular Immune Response (100)
- 4-1BB Signaling in T Lymphocytes

The bar chart data is as follows:

Pathway	$-\log[P\text{-value}]$
IL-4 Signaling	9.59
T Cell Receptor Signaling	8.91
Communication between Innate and Adaptive Immune Cells	8.55
Lipid Antigen Presentation by CD1	8.25
Regulation of IL-2 Expression in Activated and Anergic T Lymphocytes	8.19
TRIM21 Intracellular Antibody Signaling Pathway	7.18
Phagosome Formation	7.12
S100 Family Signaling Pathway	6.63
Dendritic Cell Maturation	5.90
Th1 Pathway	5.84
Systemic Lupus Erythematosus in B Cell Signaling Pathway	5.37
Macrophage Classical Activation Signaling Pathway	5.25
IL-33 Signaling Pathway	5.11

Powered by QIAGEN Digital Insights
© 2025 All Rights Reserved

QIAGEN IPA® Interpret is for molecular biology research use only and not intended for the diagnosis, prevention, or treatment of disease. Use of this content, analyses and / or results herein are subject to the QIAGEN Digital Insights User Agreement <https://www.qiagen.com/us/knowledge-and-support/ordering-support/bioinformatics-tc>

Privacy Policy Trademarks & Disclaimers Terms & Conditions

The More filters button lets you filter by pathways, molecule type, and more

Navigating your core analysis results

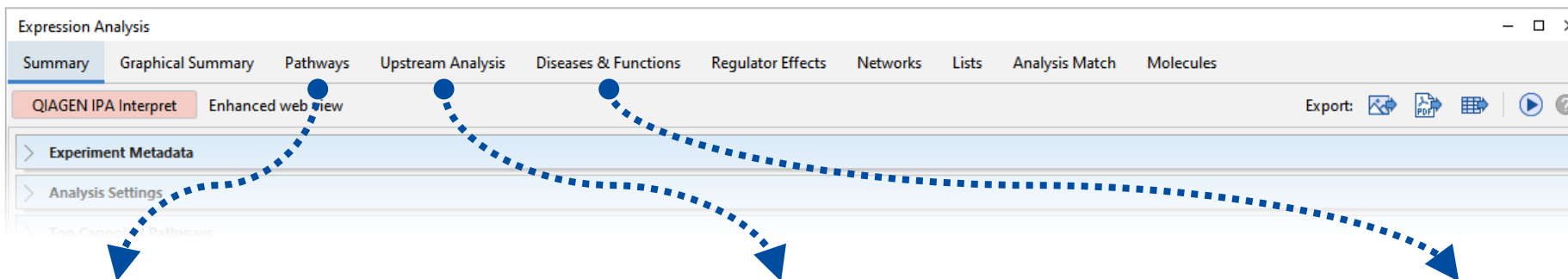

Canonical pathways

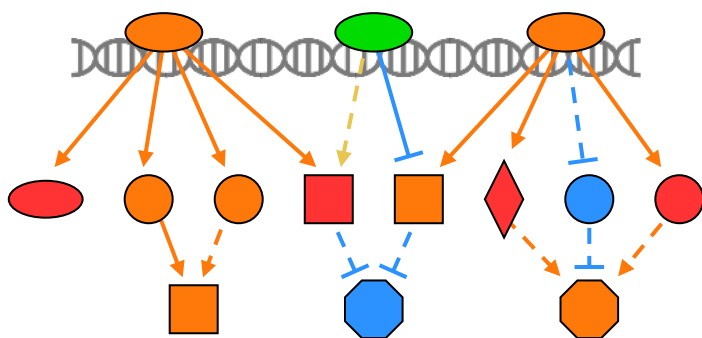

Upstream regulators

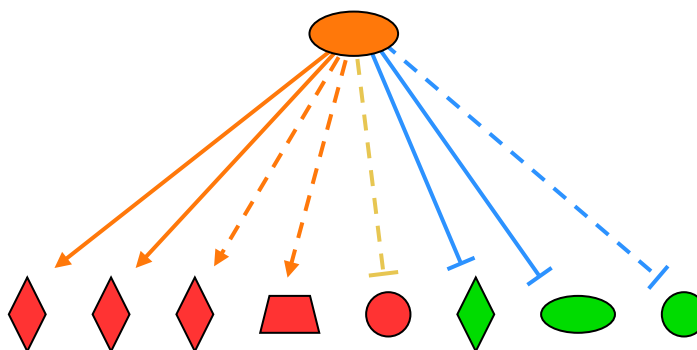

Downstream effects

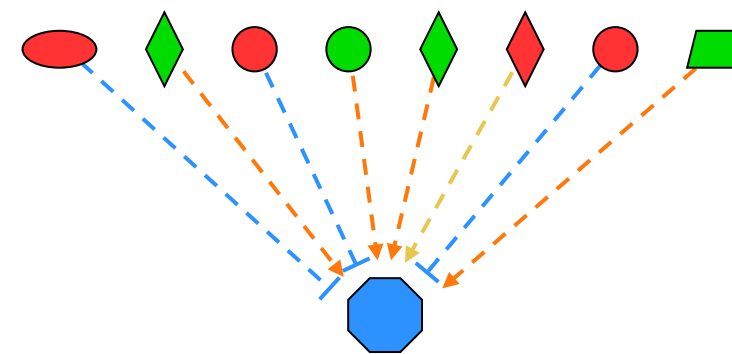

Inhibited Activated



Predicted activity change

Down Up



Observed expression

Canonical pathways: highlight key pathways and biological changes

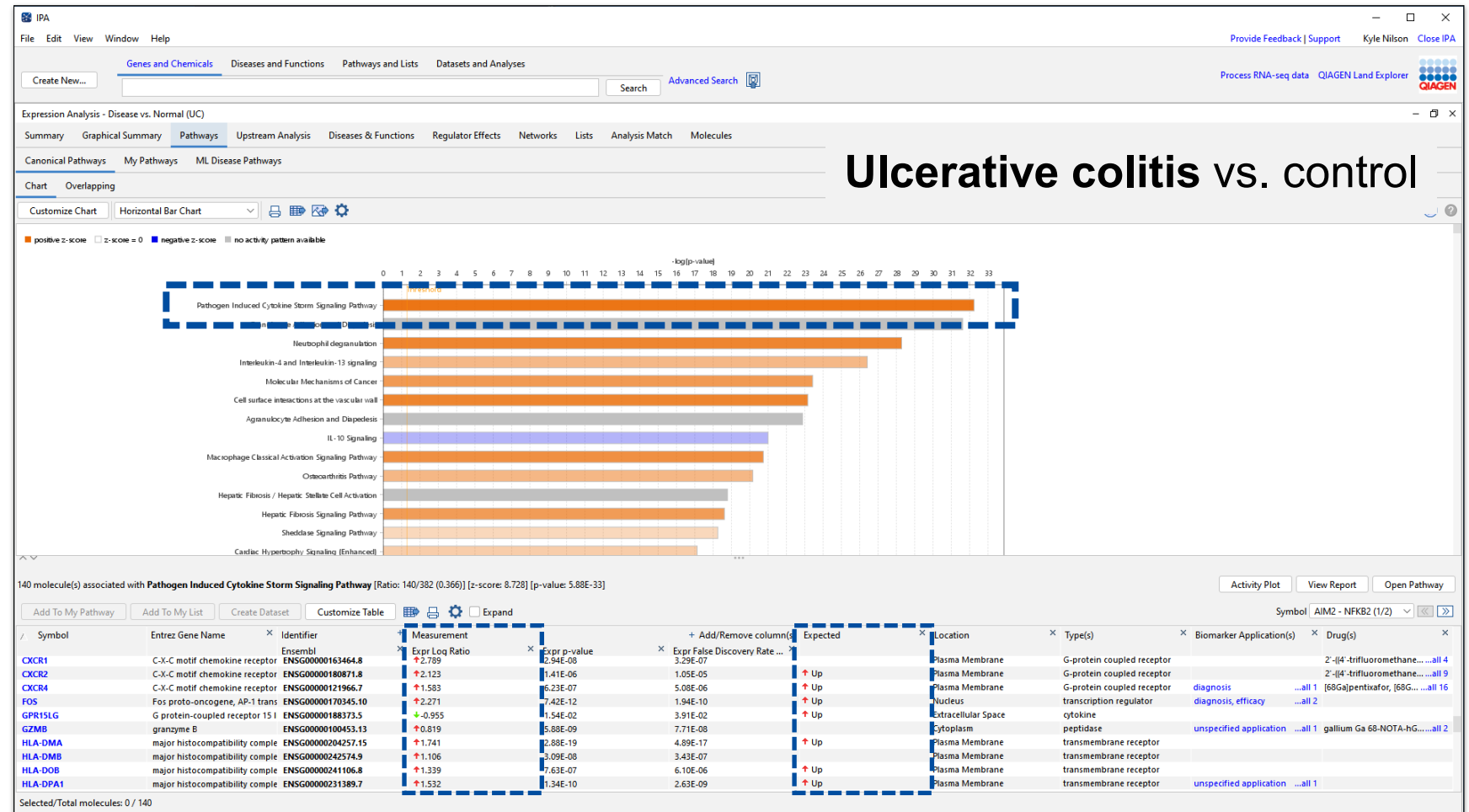

Pathways are scored by enrichment (p-value) and predicted activity (z-score)

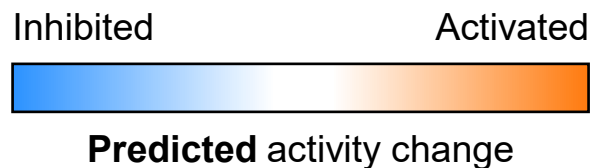

If your **observed** changes match curated expectations, IPA will assign a positive z-score and **predict** pathway activation

Canonical pathways: highlight key pathways and biological changes



Plot results multiple ways,
Bubble Chart for example

Click **Customize Chart** to filter, tweak, and prioritize

Pathways are scored by enrichment (p-value) and predicted activity (z-score)

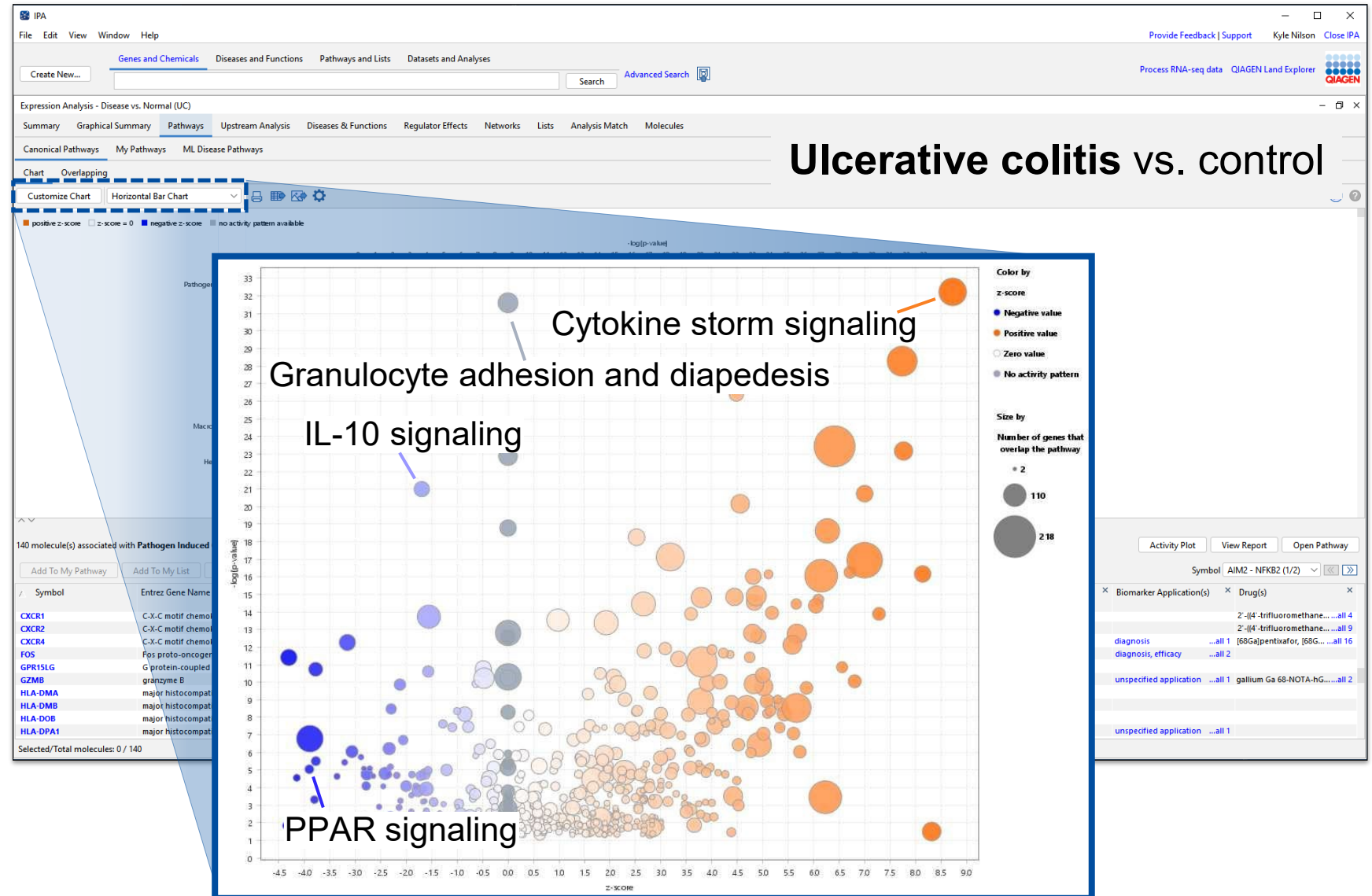

Canonical pathways: highlight key pathways and biological changes

Click **Open Pathway** to view a pathway in detail

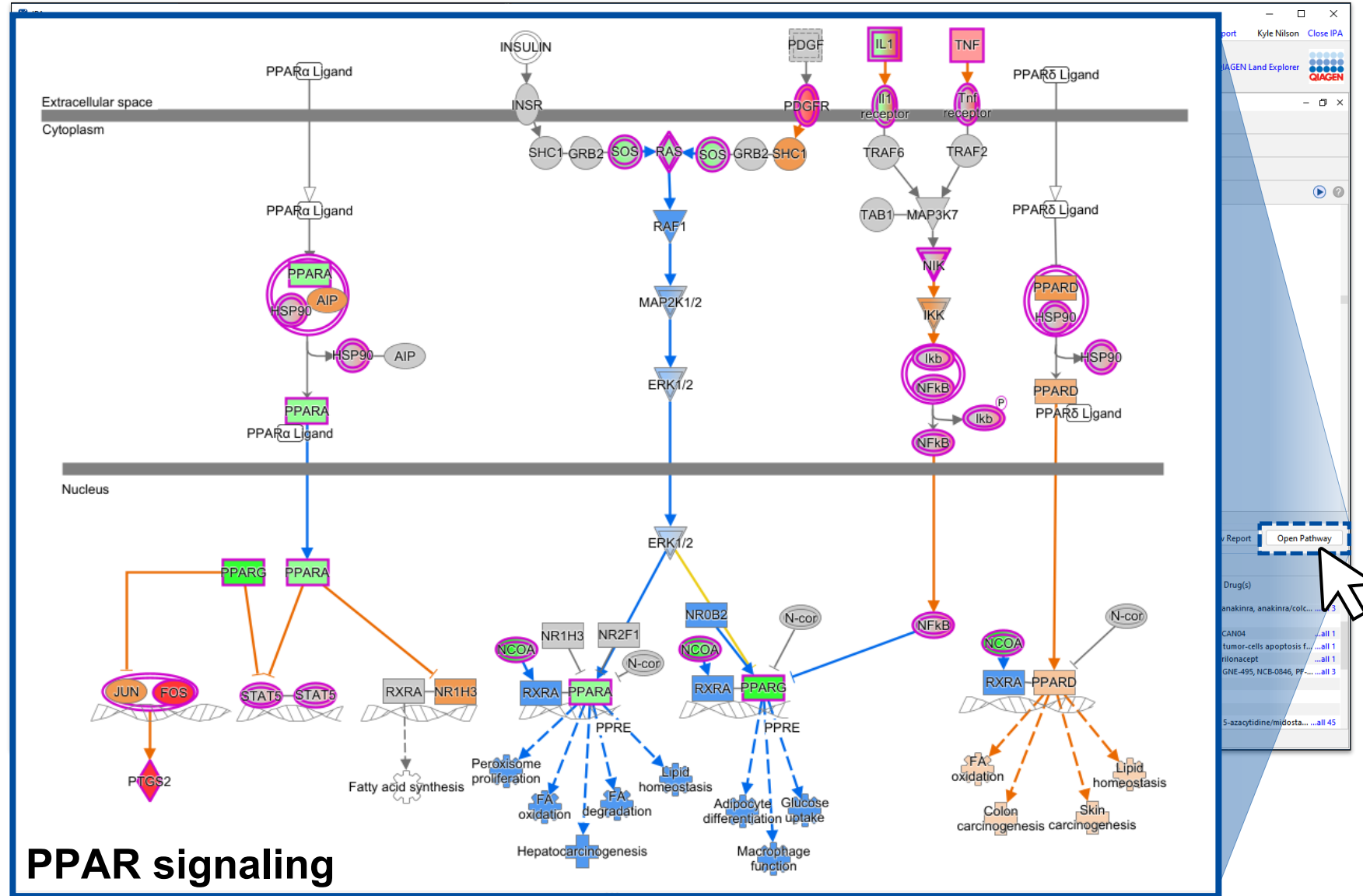
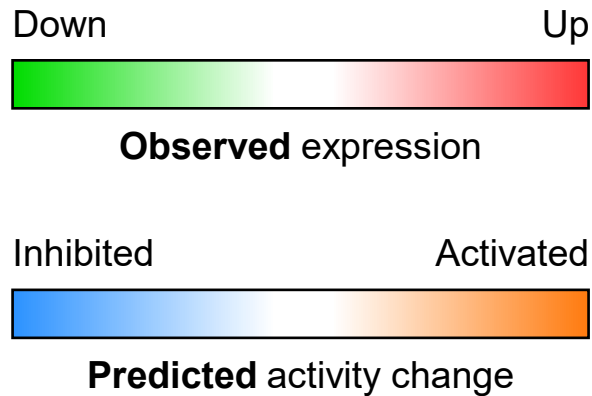

Report Kyle Nilson Close IPA

QIAGEN Land Explorer

Open Pathway

Drug(s)

- anakinra, anakinra/col... all 3
- CAN04
- tumor-cells apoptosis f... all 1
- rilonacept
- GNE-495, NCB-0946, PF... all 3
- 5-azacytidine/midosta... all 45

Upstream regulators: discover factors driving your observations

IPA

File Edit View Window Help

Genes and Chemicals Diseases and Functions Pathways and Lists Datasets and Analyses

Expression Analysis - Disease vs. Normal (UC)

Summary Graphical Summary Pathways Upstream Analysis Diseases & Functions Regulator Effects Networks Lists Analysis Match Molecules

Upstream Regulators Causal Networks

Add To My Pathway Add To My List Display as Network Activity Plot Customize Table Mechanistic Networks

Upstream Regulator	Expr Log Ratio	Molecule Type	Predicted Activation State	Activation z-score	p-value of overlap	Target Molec
COLLAGENASE (family)		group	Activated	4.347	4.36E-10	↑ADM, ↑CCL
NF- κ B (complex)		complex	Activated	3.301	4.24E-07	↓ABC1, ↑CA
COLLAGEN TYPE II (complex)		complex	Activated	2.938	5.87E-12	↑BMP6, ↑BM
SKA3		other	Activated	2.231	4.41E-03	↑HK2, ↑POK1
ELF3	0.165	transcription regulator	Activated	2.197	1.61E-07	↑ANGPTL4, ↑
ELF1	-0.343	transcription regulator	Activated	2.012	6.77E-05	↑FGF1, ↑FGF
LOC124902114	0.696	other	Activated	2.219	3.01E-05	↑CD274, ↑ID
CYLD-AS1		other	Activated	2.500	1.93E-07	↑AKR1B1, ↑B
RNF3		other	Activated	3.500	1.11E-08	↑BATF2, ↑CY
PDGFR (family)		group	Activated	2.813	8.68E-05	↑AREG, ↑CCL
CREB (family)		group	Activated	3.869	2.52E-12	↑ADM, ↑ALO
G PROTEIN ALPHA I (family)		group	Activated	4.593	5.95E-07	↑ADAMTS1, ↑
SIK/ZAP (family)		group	Activated	2.400	1.06E-02	↑CD69, ↑CDC
P3K (complex)		complex	Activated	6.559	8.65E-27	↑ADAMT2, ↑
TGF BETA (family)		group	Activated	4.732	7.25E-28	↑ABC1, ↑AB
ERK1/2 (family)		group	Activated	8.859	1.39E-35	↑ABC1, ↑AC
P38 MAPK (family)		group	Activated	6.425	3.25E-36	↑ANXAS, ↑AR
TCR (complex)		complex	Activated	6.325	1.04E-30	↑ABCD3, ↑AD
ACTIN (family)		group	Activated	2.000	1.63E-02	↑ABCC1, ↑CA
RAS HOMOLOG (family)		group	Activated	2.772	1.40E-04	↑CCN2, ↑EGF
STAT (family)		group	Activated	3.515	1.57E-05	↑A2M, ↑AGT
IFN ALPHA/BETA (family)		group	Activated	3.496	1.52E-09	↓BCL2L1, ↑C
PKC (family)		group	Activated	3.857	7.80E-19	↑ACAT1, ↑AD
MAP2K1/2 (family)		group	Activated	3.436	8.26E-08	↑ARG2, ↑ATF
CD3 (complex)		complex	Activated	7.205	1.82E-33	↑AARS1, ↑AC
NFKB (family)		group	Activated	5.958	2.32E-11	↓BSG, ↑CASP
RAS (family)		group	Activated	3.610	2.09E-20	↓ANPER, ↑AR
FIBRINOGEN (complex)		complex	Activated	2.871	5.72E-08	↑CCL2, ↑CD4
IL1 (family)		group	Activated	7.923	1.19E-45	↓ABC2, ↑AD
JNK (family)		group	Activated	7.012	1.90E-26	↑A2M, ↑ADA
ALDOSE REDUCTASE (family)		group	Activated	2.608	1.11E-02	↑CSF2, ↑CIC
MEK (family)		group	Activated	4.615	1.34E-27	↑A4GALT, ↑A
NFAT (complex)		complex	Activated	2.887	8.78E-07	↑ATF3, ↑CCL
CBP/P300 (family)		group	Activated	2.213	9.64E-02	↑BCL2A1, ↑ID
ROCK (family)		group	Activated	2.646	1.50E-05	↑CAVIN1, ↑C
FGF (family)		group	Activated	2.929	2.05E-03	↑FOS, ↑JUNB
VEGF (family)		group	Activated	7.525	1.11E-64	↑A2M, ↑ABCE
SMAD2/3 (family)		group	Activated	2.397	1.13E-03	↓ABC2, ↑AC
IL1R (family)		group	Activated	6.276	2.20E-22	↑AREG, ↑CCL
MAPK (family)		group	Activated	4.338	1.35E-13	↓ABC1, ↑AD

Selected 1 / 4163

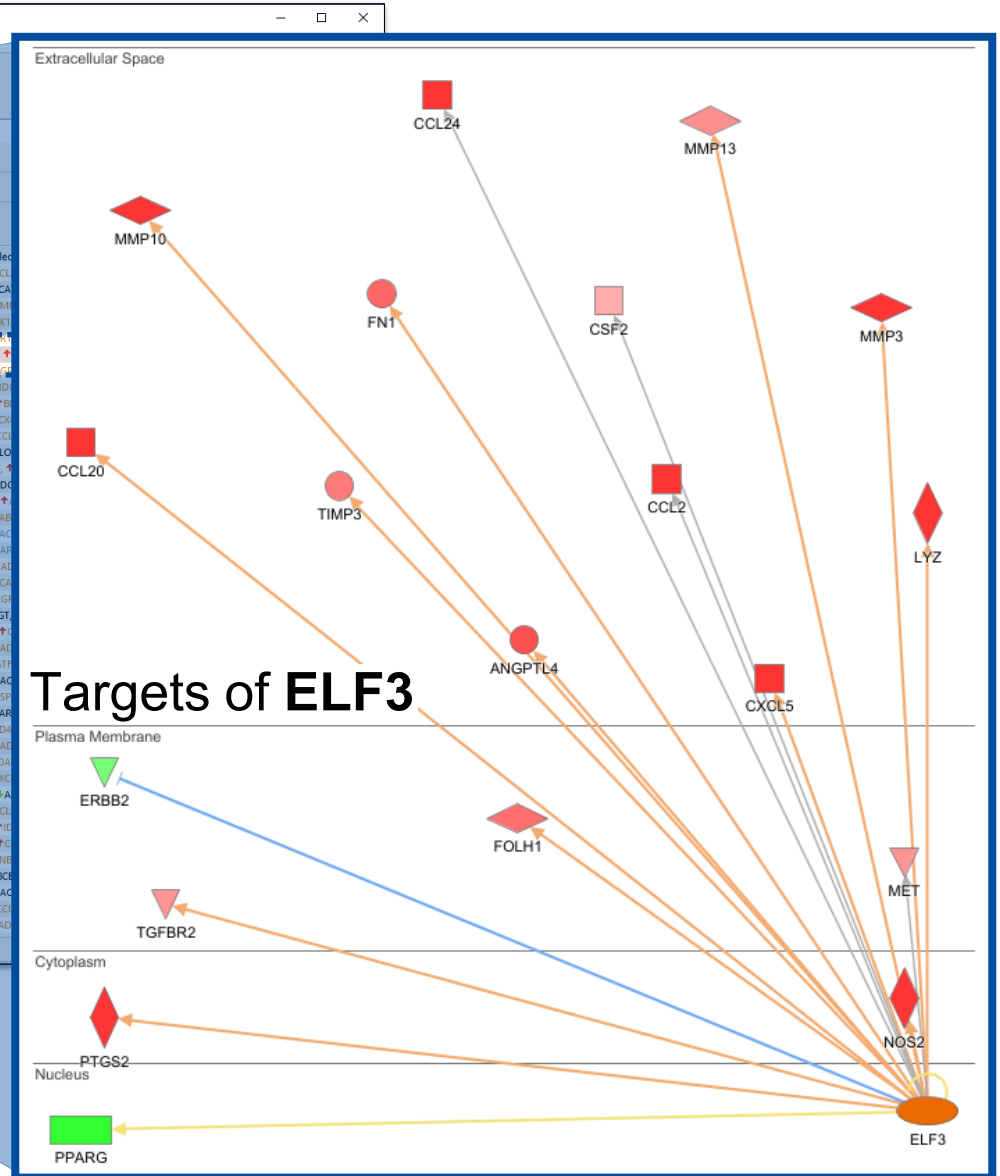

Ulcerative colitis vs. control

Agenda

Perform pathway analysis on your own 'omics data

Compare and contextualize your results with other studies

Build networks from scratch and explore relationships

Options to tackle differential expression before using IPA





Compare and contextualize your results with other studies

Comparison Analysis

- Open as many as 20 IPA analysis results side-by-side
- Load pathway-specific gene heatmaps to focus your biomarker search

Analysis Match

- Compare your results against 260,000+ curated studies
- Discover conditions directionally similar or opposite to your results



Comparison analysis: quickly view up to 20 analyses side-by-side

Atopic dermatitis

- CTLA4 Signaling in Cytotoxic ...
- Pathogen Induced Cytokine S...
- FAK Signaling
- IL-4 Signaling
- T Cell Receptor Signaling
- Regulation of IL-2 Expression ...
- G Protein Signaling Mediated...
- Role Of Osteoclasts In Rheu...
- S100 Family Signaling Pathway
- Multiple Sclerosis Signaling P...
- Wound Healing Signaling Pat...
- Dendritic Cell Maturation
- Phagosome Formation
- Macrophage Classical Activat...
- IL-17 Signaling
- Role Of Chondrocytes In Rhe...
- Role of Hypercytokinemia/hy...
- Crosstalk between Dendritic ...
- HMGB1 Signaling
- Systemic Lupus Erythematosu...
- TREM1 Signaling
- IL-33 Signaling Pathway
- Role of NFAT in Regulation of...
- PKCθ Signaling in T Lymphocy...
- NOD1/2 Signaling Pathway

lesional vs. non-lesional
cyclosporine vs. control
dupilumab vs. control

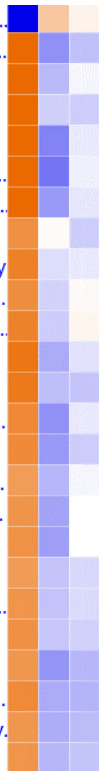

- PIK3R5
- TRGV4
- TRBV19
- TRGV5
- TRBV27
- TRBV7-9
- HLA-DRB1
- NFKB2
- PTGDR2
- TRAV14DV4
- CCL22
- HLA-DOB
- BATF
- ANO1
- HRAS
- TRAV3
- TRAV26-2
- IRF4
- TRAV19
- SOCS1
- TRBV28
- MMP12
- CCL11
- TRAV25
- TRAV6
- TRBV12-3
- TRBV14
- TRAV1-2
- COL6A6
- COL6A5
- FCER2
- IGHE

AD
cyclosporine
dupilumab

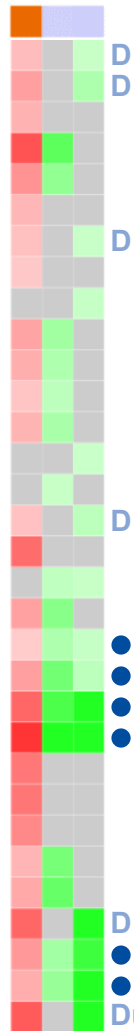

Dupilumab-specific?

Dupilumab vs. pre-treatment (AD) IL-4 signaling

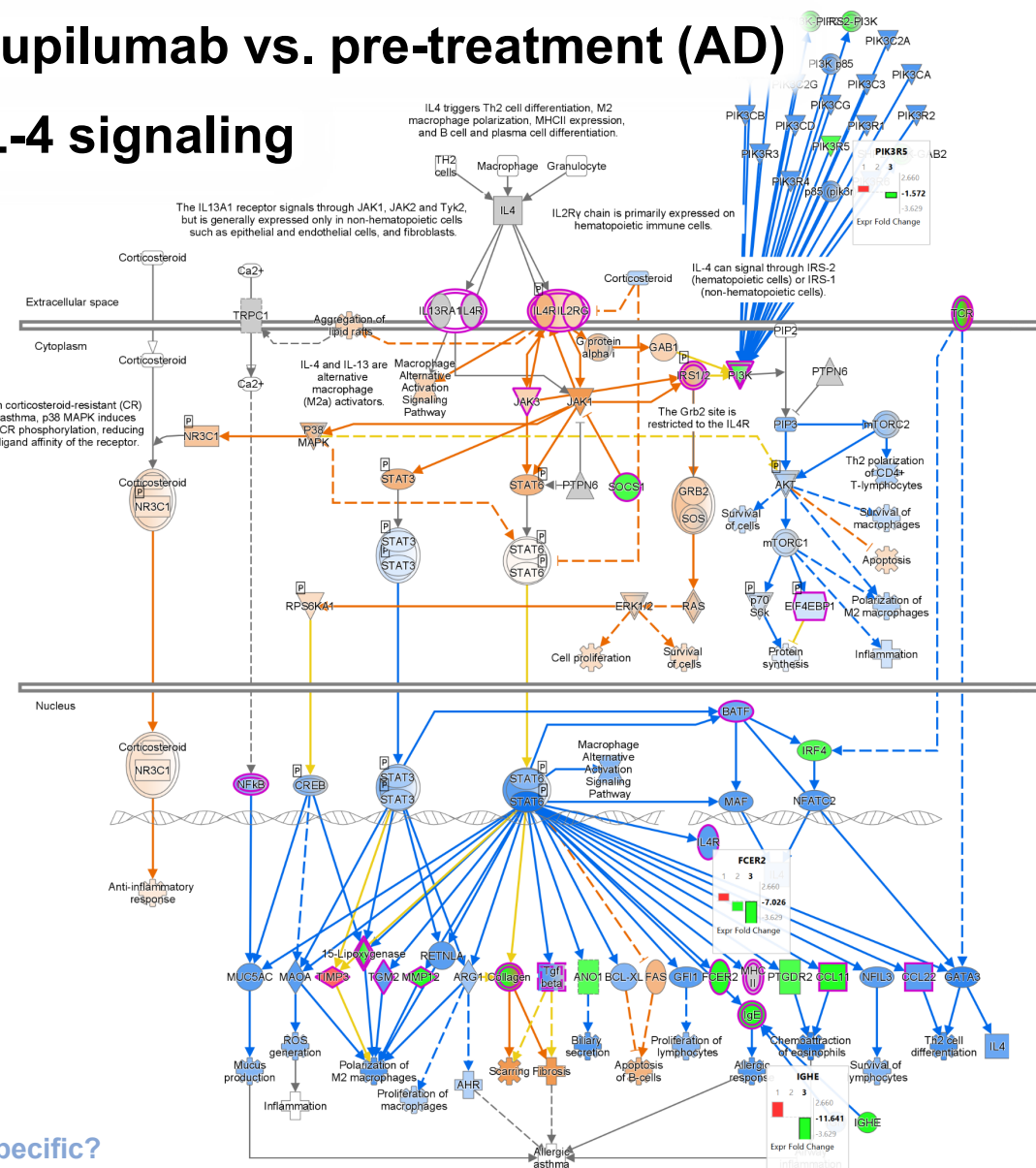

Comparison analysis: quickly view up to 20 analyses side-by-side

Vedolizumab (6, 12, 28, or 52 wk)
or **Infliximab (4-6 wk)** vs. control

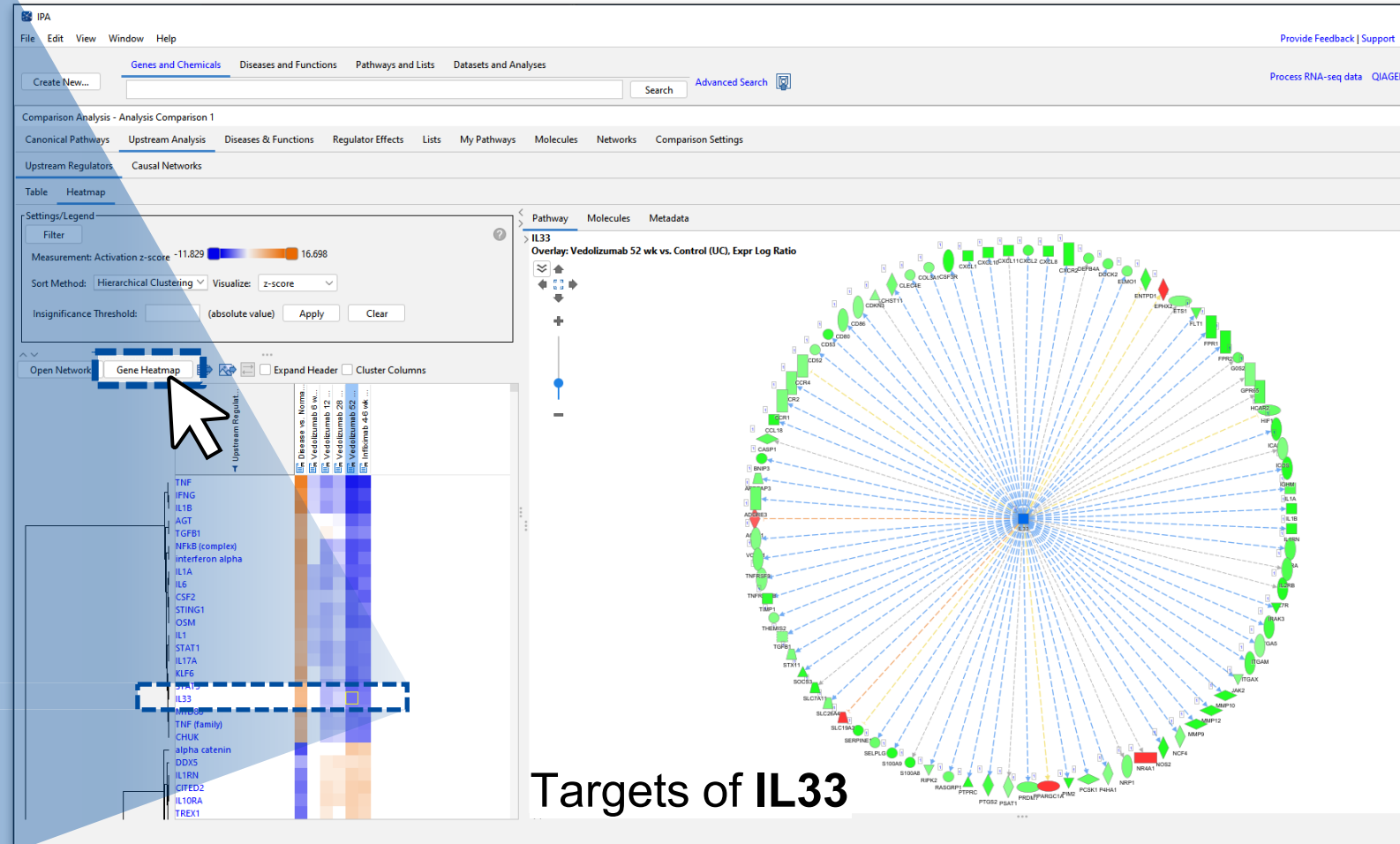
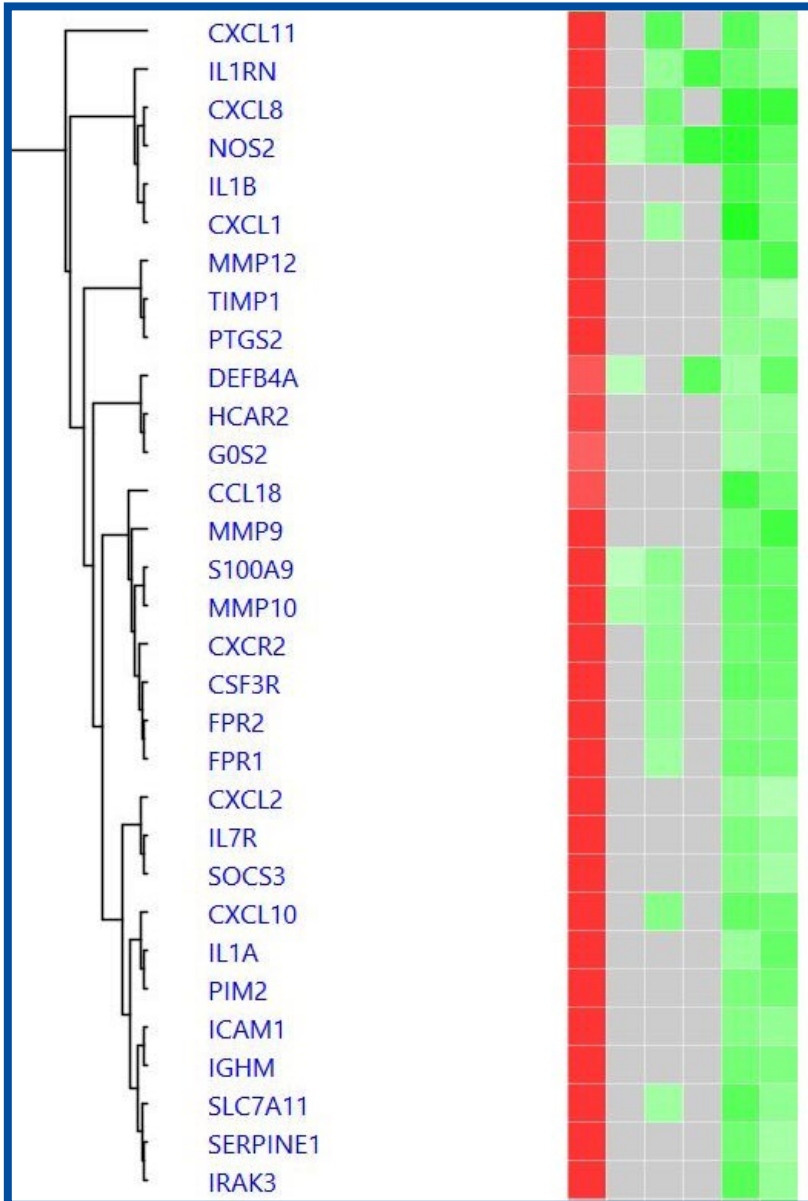

Targets of IL33

Analysis Match: bringing causal insights to real world data



413,000+ comparisons

Case vs. control results from over 1 million curated samples
[log2FC, p-values]



260,000+ IPA results

Activity prediction and pathway enrichment scores
[z-scores, p-values]

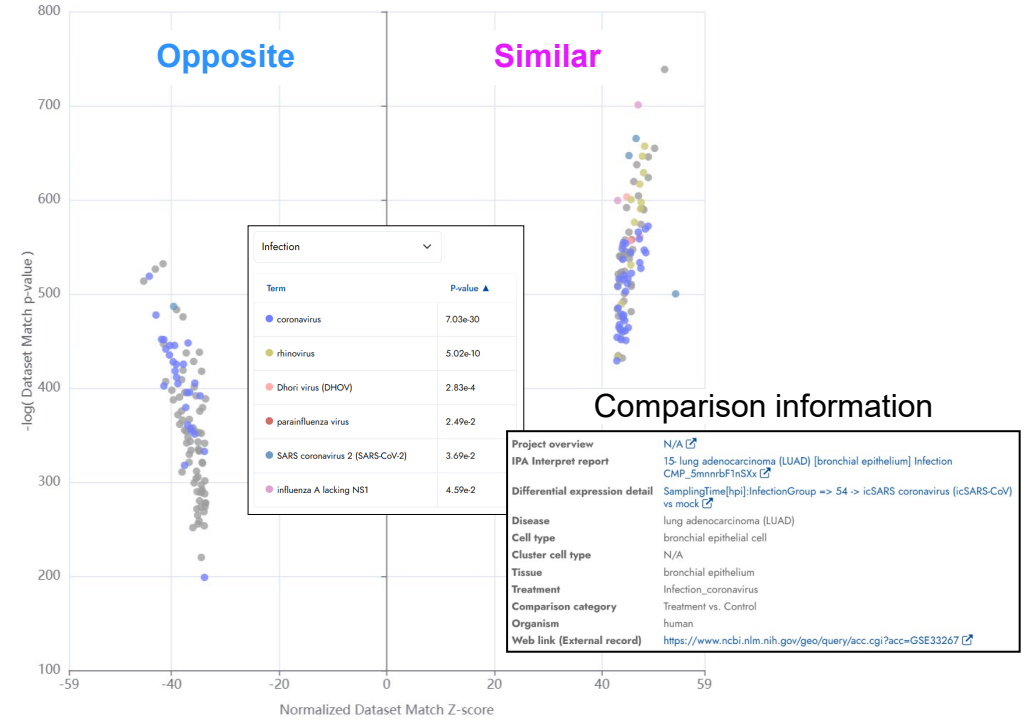
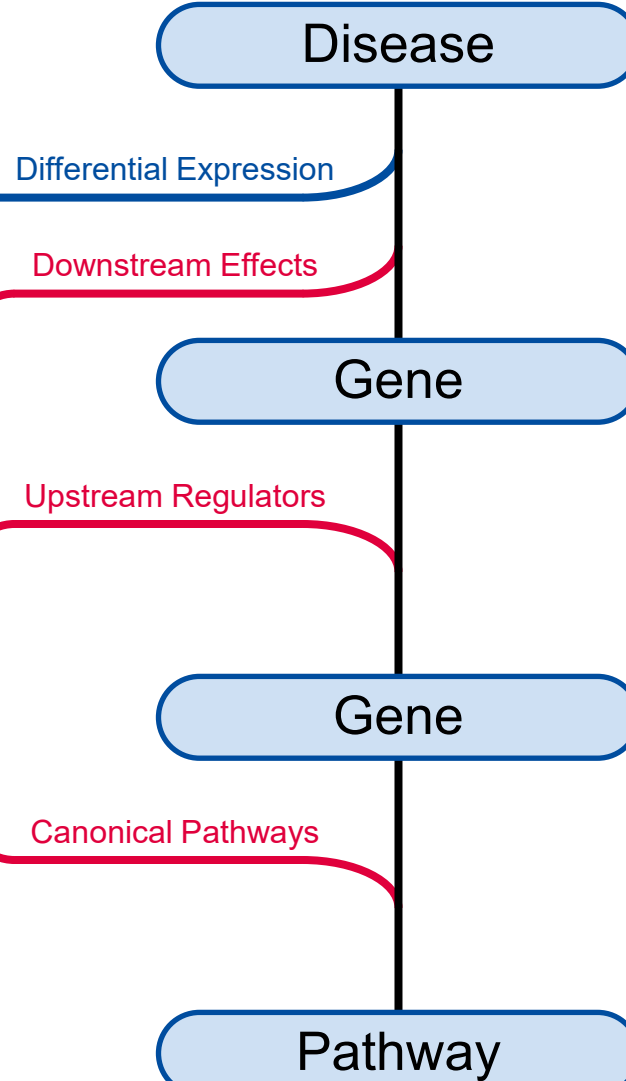

Analysis Name	case.diseasestate	comparisoncategory	comparisoncontrast	CP...	UR...	CNL...	DE...	DM...
ESE73661_UC_Vedolizumab S2 wk vs. Control (UC)				82.20	87.18	80.62	85.80	86.45
ESE73661_UC_Vedolizumab Response vs. No Response (UC)				86.60	86.02	80.00	87.40	85.91
ESE73661_IBD_Vedolizumab-w-metadatas - 2023-07-01 10:54 AM, 5 ulcerative colitis (UC)				89.44	84.85	73.48	81.65	82.26
ESE73661_UC_Infliximab 4-6 wk vs. Control (UC)				70.71	84.26	80.62	88.19	80.95
1. ulcerative colitis (UC) [colonic mucosa] NA 28255	ulcerative colitis (UC)	Treatment vs. Control	SubjectTreatment:SamplingTime:DiseaseStage => placeboactive disea...	80.62	87.18	79.37	76.38	80.89
8. ulcerative colitis (UC) [colonic mucosa] NA 30200	ulcerative colitis (UC)	Responder vs. Non-Respon...	ResponseTreatmentStatus => infliximab -> response vs no response	80.62	81.05	80.00	76.30	79.71
5. ulcerative colitis (UC) [colonic mucosa] NA 30194	ulcerative colitis (UC)	Treatment vs. Control	TreatmentStatus => vedolizumab vs none	70.71	86.02	77.46	70.71	76.23
16. thyroid eye disease [lacrimal gland] NA 27572	thyroid eye disease	Responder vs. Disease2	TissueDiseaseState => lacrimal gland -> thyroid eye disease vs sarcos...	59.16	86.60	75.50	78.17	74.86
43. ulcerative colitis (UC) [colonic mucosa] NA 17982	ulcerative colitis (UC)	Responder vs. Non-Respon...	DiseaseState:SamplingTime:Response => ulcerative colitis (UC)week 4...	70.71	79.37	74.83	73.60	74.63
80. crohn's disease (CD) [sigmoid colon] NA 12002	crohn's disease (CD)	Treatment vs. Control	TissueExperimentGroup:SamplingTime:SamplingTime => sigmoid...	67.08	83.85	75.50	73.69	69.06
1. lupus nephritis (LN) [kidney] NA 2391	lupus nephritis (LN)	Disease vs. Normal	SamplingTime:DiseaseState => week 12 -> lupus nephritis (LN) vs nor...	-67.08	-82.46	-67.82	-79.06	-74.11
3. crohn's disease (CD) [sigmoid colon] NA 56	crohn's disease (CD)	Disease vs. Normal	TissueDiseaseState => sigmoid colon -> crohn's disease (CD) vs norm...	-74.10	-73.48	-76.81	-72.65	-74.28
7. urinary tract obstruction [kidney] NA 7478	urinary tract obstruction	Disease vs. Normal	DiseaseState:Genotype => wild type -> urinary tract obstruction vs no...	-74.16	-83.07	-76.81	-84.55	-74.65
2. ulcerative colitis (UC) [colonic mucosa] NA 28367	ulcerative colitis (UC)	Disease vs. Normal	DiseaseState:TissueRegion => left -> ulcerative colitis (UC) vs normal co...	-67.08	-81.85	-76.16	-75.46	-81.13
2. ureteral obstruction [kidney] NA 8851	ureteral obstruction	Treatment vs. Control	SamplingTime -> day 8 vs pre-treatment	-77.46	-81.24	-69.28	-72.65	-75.16
1. crohn's disease (CD) [colonic mucosa] NA 4133	crohn's disease (CD)	Disease vs. Disease2	DiseaseState => crohn's disease (CD) vs disease control	-67.08	-86.02	-78.10	-72.65	-75.96
4. crohn's disease (CD) [colonic mucosa] NA 20419	crohn's disease (CD)	Disease vs. Normal	TissueExperimentGroup => colonic mucosa -> crohn's disease active	-37.46	-81.85	-69.28	-76.38	-76.34
3. crohn's disease (CD) [colonic mucosa] NA 27620	crohn's disease (CD)	Disease vs. Normal	ExperimentGroup => crohn's disease active disease vs normal control	-77.46	-81.85	-69.28	-76.38	-76.34
3. ulcerative colitis (UC) [colonic mucosa] NA 26117	ulcerative colitis (UC)	Other Comparisons	DiseaseStage => active disease vs inactive disease	-77.46	-79.37	-75.50	-77.28	-77.40
ESE73661_UC_Disease vs. Normal (UC)				-77.46	-87.75	-72.11	-76.38	-78.42
11CP-high_heat_muscle - 2023-06-08 11:11 AM, ESE438323.GP2				39.71	-89.60	-75.50	-81.65	-78.62
ESE73661_IBD_Vedolizumab-w-metadatas - 2023-07-01 10:54 AM, 1 ulcerative colitis (UC)				-83.67	-88.88	-78.74	-77.28	-82.14

Comparison information

Similar
Opposite

Analysis Match: use your entire study as a directional query



Infliximab response vs. no response (ulcerative colitis)

Expression Analysis - Infliximab Response vs. No Response (UC)

Summary Graphical Summary Pathways Upstream Analysis Diseases & Functions Regulator Effects Networks Lists Analysis Match Molecules

Evaluate Metadata View As Heatmap View Comparison Customize Table

Analysis Name	case.diseasestate	comparisoncategory	comparisoncontrast	CP ...	UR ...	CN...	DE ...	DM...
GSE73661_UC, Vedolizumab 52 wk vs. Control (UC)				92.20	87.18	80.62	85.80	86.45
GSE73661_UC, Vedolizumab Response vs. No Response (UC)				86.60	86.02	80.00	87.40	85.01
GSE73661-IBD-Vedolizumab-w-metadata - 2023-07-01 10:54 AM, 5 ulcerative colitis (UC)				89.44	84.85	73.48	81.65	82.36
GSE73661_UC, Infliximab 4-6 wk vs. Control (UC)				70.71	84.26	80.62	88.19	80.95
1- ulcerative colitis (UC) [colonic mucosa] NA 26255	ulcerative colitis (UC)	Treatment vs. Control	SubjectTreatment:SamplingTime:DiseaseStage => placebo:active disea...	80.62	87.18	79.37	76.38	80.89
8- ulcerative colitis (UC) [colonic mucosa] NA 30200	ulcerative colitis (UC)	Responder vs. Non-Respon...	Response:TreatmentStatus => infliximab -> response vs no response	80.62	81.85	80.00	76.38	79.71
2- ulcerative colitis (UC) [colonic mucosa] NA 30194	ulcerative colitis (UC)	Treatment vs. Control	TreatmentStatus => vedolizumab vs none	70.71	86.02	77.46	70.71	76.23
16- thyroid eye disease [lacrimial gland] NA 27572	thyroid eye disease	Disease1 vs. Disease2	Tissue:DiseaseState => lacrimal gland -> thyroid eye disease vs sarcoi...	59.16	86.60	75.50	78.17	74.86
43- ulcerative colitis (UC) [colonic mucosa] NA 17982	ulcerative colitis (UC)	Responder vs. Non-Respon...	DiseaseState:SamplingTime:Response => ulcerative colitis (UC):week 4...	70.71	79.37	74.83	73.60	74.63
98- crohn's disease (CD) [sigmoid colon] NA 12202	crohn's disease (CD)	Treatment vs. Control	Tissue:ExperimentGroup:SamplePathology:SamplingTime => sigmoid ...	67.08	81.85	75.50	71.69	74.03
1- lupus nephritis (LN) [kidney] NA 23391	lupus nephritis (LN)	Disease vs. Normal	SamplingTime:DiseaseState => week 12 -> lupus nephritis (LN) vs nor...	-67.08	-82.46	-67.82	-79.06	-74.11
3- crohn's disease (CD) [sigmoid colon] NA 56	crohn's disease (CD)	Disease vs. Normal	Tissue:DiseaseState => sigmoid colon -> crohn's disease (CD) vs norm...	-74.16	-73.48	-76.81	-72.65	-74.28
7- urinary tract obstruction [kidney] NA 7478	urinary tract obstruction	Disease vs. Normal	DiseaseState:Genotype => wild type -> urinary tract obstruction vs no...	-74.16	-83.07	-76.81	-64.55	-74.65
2- ulcerative colitis (UC) [colonic mucosa] NA 28367	ulcerative colitis (UC)	Disease vs. Normal	DiseaseState:TissueRegion => left -> ulcerative colitis (UC) vs normal c...	-67.08	-81.85	-76.16	-75.46	-75.14
2- ureteral obstruction [kidney] NA 8851	ureteral obstruction	Treatment vs. Control	SamplingTime => day 8 vs pre-treatment	-77.46	-81.24	-69.28	-72.65	-75.16
1- crohn's disease (CD) [colonic mucosa] NA 4133	crohn's disease (CD)	Disease1 vs. Disease2	DiseaseState => crohn's disease (CD) vs disease control	-67.08	-86.02	-78.10	-72.65	-75.96
4- crohn's disease (CD) [colonic mucosa] NA 30419	crohn's disease (CD)	Disease vs. Normal	Tissue:ExperimentGroup => colonic mucosa -> crohn's disease active ...	-77.46	-81.85	-69.28	-76.38	-76.24
2- crohn's disease (CD) [colonic mucosa] NA 27630	crohn's disease (CD)	Disease vs. Normal	ExperimentGroup => crohn's disease active disease vs normal control	-77.46	-81.85	-69.28	-76.38	-76.24
3- ulcerative colitis (UC) [colonic mucosa] NA 26117	ulcerative colitis (UC)	Other Comparisons	DiseaseStage => active disease vs inactive disease	-77.46	-79.37	-75.50	-77.28	-77.40
GSE73661_UC, Disease vs. Normal (UC)				-77.46	-87.75	-72.11	-76.38	-78.42
TGFb-high_heart-muscle - 2023-06-06 11:11 AM, GSE143323.GPL2				-70.71	-86.60	-75.50	-81.65	-78.62
GSE73661-IBD-Vedolizumab-w-metadata - 2023-07-01 10:54 AM, L ulcerative colitis (UC)				-83.67	-88.88	-78.74	-77.28	-82.14

Selected 0 / 22

Directionally similar

Directionally opposite

Comparison information

260,000+ pre-computed curated studies and your previous IPA analyses, all in one query

Average z-score

- Disease enrichment
- Causal networks
- Upstream regulators
- Canonical pathways

Drug repurposing and indication selection using curated IPA results



The directional opposite of **disease vs. normal** is treatment vs. no treatment

The directional opposite of **treatment vs. no treatment** is disease vs. normal

Find directionally-opposite public studies to identify new indications

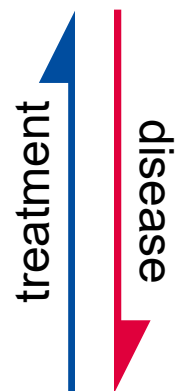

Dupilumab vs. pre-treatment (atopic dermatitis)

Expression Analysis - Dupilumab vs Untreated (Lesion)

Summary Graphical Summary Pathways Upstream Analysis Diseases & Functions Regulator Effects Networks Lists Analysis Match Molecules

Evaluate Metadata View As Heatmap View Comparison Customize Table

z-sc... -54.16 - -30.89 (1/23)

Analysis Name	Project	case.diseasestate	compariso...	comparisoncontrast	comp...	weblink	CP (z-...)	UR (z-...)	CN (z-...)	DE (z-...)	z-...
18- hidradenitis suppurativa	HumanDisease	hidradenitis suppurativa	Disease vs. Normal	ExperimentGroup2 => no response during treatment, lesion...	GSE155176.GPL1	https://www.nc...	-70.71	-37.52	-38.73	-69.69	-54.16
1- colitis [colon] NA 20687	MouseDisease	colitis	Disease vs. Normal	TissueRegionDiseaseState => distal colon -> colitis vs nor...	GSE64658.GPL1	https://www.nc...	-70.71	-39.95	-37.42	-58.55	-51.66
2- colon adenocarcinoma (C)	MouseDisease	colon adenocarcinoma (COAD)	Disease vs. Normal	TissueRegionDiseaseState => distal colon -> colon adenoc...	GSE64658.GPL1	https://www.nc...	-70.71	-39.95	-31.62	-58.55	-50.21
1- acute liver failure;hepatiti	HumanDisease	acute liver failure;hepatitis B	Disease vs. Normal	DiseaseState => acute liver failure;hepatitis B vs normal con...	GSE14668.GPL5	https://www.nc...	-70.71	-32.62	-28.28	-63.25	-48.71
3- renal clear cell carcinoma	OncoHuman	renal clear cell carcinoma (KIRC)	Disease vs. Normal	DiseaseState => renal clear cell carcinoma (KIRC) vs control	GSE15641.GPL9	https://www.nc...	-70.71	-34.04	-26.46	-58.55	-47.44
1- acute liver failure;hepatiti	HumanDisease	acute liver failure;hepatitis B	Disease vs. Normal	DiseaseState => acute liver failure;hepatitis B vs normal con...	GSE38941.GPL5	https://www.nc...	-70.71	-33.08	-21.21	-63.25	-47.06
22- hidradenitis suppurativa	HumanDisease	hidradenitis suppurativa	Disease vs. Normal	ExperimentGroup2 => partial response pre-treatment, lesio...	GSE155176.GPL1	https://www.nc...	-70.71	-44.96	-40.00	-69.69	-38.66
1- colorectal cancer [colon] ↑	OncoHuman	colorectal cancer	Disease vs. Normal	SampleOrigin:ExperimentGroup => colon -> tumor tissue vs ...	GSE141174.GPL1	https://www.nc...	-70.71	-29.77	-	-53.45	-38.48
24- hidradenitis suppurativa	HumanDisease	hidradenitis suppurativa	Disease vs. Normal	ExperimentGroup2 => response during treatment, lesional v...	GSE155176.GPL1	https://www.nc...	-70.71	-46.13	-37.42	-69.69	-38.31
1- hidradenitis suppurativa [↓]	HumanDisease	hidradenitis suppurativa	Disease vs. Normal	DiseaseState => hidradenitis suppurativa vs normal control	GSE115099.GPL1	https://www.nc...	-70.71	-42.53	-42.43	-67.61	-38.14
26- hidradenitis suppurativa	HumanDisease	hidradenitis suppurativa	Disease vs. Normal	ExperimentGroup2 => response pre-treatment, lesional vs n...	GSE155176.GPL1	https://www.nc...	-70.71	-43.76	-37.42	-69.69	-37.72
1- atopic dermatitis [skin] N/	HumanDisease	atopic dermatitis	Disease vs. Normal	ExperimentGroup => atopic dermatitis lesional vs normal co...	GSE121212.GPL1	https://www.nc...	-70.71	-48.38	-34.64	-67.61	-37.66
6- benign familial hematuria	MouseDisease	benign familial hematuria	Disease vs. Normal	DiseaseState:Genotype => wild type -> benign familial hem...	GSE55808.GPL1	https://www.nc...	-70.71	-38.59	-36.06	-75.59	-37.56
20- hidradenitis suppurativa	HumanDisease	hidradenitis suppurativa	Disease vs. Normal	ExperimentGroup2 => no response pre-treatment, lesional v...	GSE155176.GPL1	https://www.nc...	-70.71	-44.96	-33.17	-71.71	-37.46
5- mycosis fungoides [lymph	Hematology	mycosis fungoides	Disease vs. Normal	TissueDescription => plaque vs normal	GSE59307.GPL1	https://www.nc...	-70.71	-43.76	-36.06	-69.69	-37.38
6- allergic asthma [lung] NA	MouseDisease	allergic asthma	Disease vs. Normal	DiseaseState:SamplingTime[hours] => 6 -> allergic asthma ...	GSE41665.GPL1	http://www.ncbi...	-70.71	-47.27	-30.00	-71.71	-37.24
1- psoriasis [skin] NA 7942	MouseDisease	psoriasis	Disease vs. Normal	DiseaseState:AnimalStrainGender => 129X1/SvJfemale -> ...	GSE86315.GPL1	https://www.nc...	-70.71	-37.19	-36.06	-75.59	-37.21
2- asthmatic CRS [nasosinus	HumanDisease	asthmatic CRS	Disease vs. Normal	DiseaseState => asthmatic CRS vs normal control	GSE23552.GPL5	http://www.ncbi...	-70.71	-39.95	-41.23	-67.61	-37.20
7- urinary tract obstruction [↓]	MouseDisease	urinary tract obstruction	Disease vs. Normal	DiseaseState:Genotype => wild type -> urinary tract obstru...	GSE55808.GPL1	https://www.nc...	-70.71	-39.95	-33.17	-75.59	-37.18
14- atopic dermatitis [skin] ↓	MouseDisease	atopic dermatitis	Disease vs. Normal	DiseaseState:AgeRange[weeks] => 8 -> atopic dermatitis vs...	GSE86071.GPL1	https://www.nc...	-70.71	-39.95	-34.64	-73.68	-37.07
1- chronic obstructive pulmo	MouseDisease	chronic obstructive pulmonary dis...	Disease vs. Normal	DiseaseState => chronic obstructive pulmonary disease (CO...	GSE38075.GPL6	http://www.ncbi...	-70.71	-38.90	-38.73	-69.69	-36.83
4- obesity [subcutaneous adi	HumanDisease	obesity	Disease vs. Normal	Tissue:DiseaseState => subcutaneous adipose tissue -> obe...	GSE151839.GPL1	https://www.nc...	-70.71	-35.49	-40.00	-71.71	-36.80
7- allergic contact dermatitis	HumanDisease	allergic contact dermatitis (ACD)	Disease vs. Normal	ExperimentGroup:DiseaseState => nickel sulfate 96 hours ...	GSE6281.GPL57	https://www.nc...	-70.71	-46.13	-34.64	-65.47	-36.56
2- atopic dermatitis [skin] N/	HumanDisease	atopic dermatitis	Disease vs. Normal	ExperimentGroup => atopic dermatitis non-lesional vs norm...	GSE121212.GPL1	https://www.nc...	-70.71	-43.76	-38.73	-63.25	-36.43
1- atopic dermatitis [skin] N/	MouseDisease	atopic dermatitis	Disease vs. Normal	DiseaseState => atopic dermatitis vs normal control	GSE90883.GPL2	https://www.nc...	-70.71	-42.53	-33.17	-69.69	-36.35
3- crohn's disease (CD) [sigir	HumanDisease	crohn's disease (CD)	Disease vs. Normal	Tissue:DiseaseState => sigmoid colon -> crohn's disease (C...	E-MTAB-5464.G1	http://www.ebi...	-70.71	-37.52	-37.42	-69.69	-36.16
1- dermatitis [skin] NA 6051	MouseDisease	dermatitis	Disease vs. Normal	DiseaseState => dermatitis vs normal control	GSE65686.GPL1	https://www.nc...	-70.71	-36.10	-38.73	-69.69	-36.13
1- chronic idiopathic urticari	HumanDisease	chronic idiopathic urticaria	Disease vs. Normal	SamplePathology => lesional vs normal	GSE57178.GPL6	https://www.nc...	-70.71	-40.23	-38.73	-65.47	-36.11
2- psoriasis vulgaris [skin] N/	HumanDisease	psoriasis vulgaris	Disease vs. Normal	DiseaseState => psoriasis vulgaris vs normal control	GSE57225.GPL1	http://www.ncbi...	-70.71	-39.95	-34.64	-69.69	-36.07
1- viral infectious disease [hi	MouseDisease	viral infectious disease	Disease vs. Normal	DiseaseState => viral infectious disease vs normal control	GSE72139.GPL6	https://www.nc...	-70.71	-37.19	-33.17	-73.68	-36.01
3- pulmonary fibrosis [lung] ↑	MouseDisease	pulmonary fibrosis	Disease vs. Normal	SamplingTime[days]:DiseaseState => 2 -> pulmonary fibrosi...	GSE40151.GPL1	http://www.ncbi...	-70.71	-38.59	-33.17	-71.71	-35.87
https://www.nc...							-70.71	-41.26	-41.23	-60.94	-35.86
https://www.nc...							-70.71	-34.21	-41.23	-67.61	-35.76
https://www.nc...							-70.71	-47.27	-34.64	-60.94	-35.71
https://www.nc...							-70.71	-44.96	-30.00	-67.61	-35.64
https://www.nc...							-70.71	-43.76	-33.17	-65.47	-35.60
1- atopic dermatitis [epiderm	MouseDisease	atopic dermatitis	Disease vs. Normal	Tissue:DiseaseState => epidermis -> atopic dermatitis vs n...	GSE107687.GPL1	https://www.nc...	-70.71	-38.90	-31.62	-71.71	-35.56
5- psoriasis [skin] NA 17439	MouseDisease	psoriasis	Disease vs. Normal	TissueRegionDiseaseState => ear skin -> psoriasis vs norm...	GSE27628.GPL1	http://www.ncbi...	-70.71	-42.53	-30.00	-69.69	-35.55

Selected 0 / 4490

Dupilumab might be effective for some of these alternative indications

Find directionally-opposite public studies to repurpose drugs

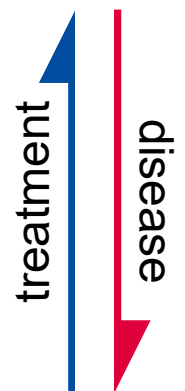

Lesional vs. non-lesional (atopic dermatitis)

Expression Analysis - Lesional vs Non-Lesional (Atopic Derm.)

Summary Graphical Summary Pathways Upstream Analysis Diseases & Functions Regulator Effects Networks Lists Analysis Match Molecules

Evaluate Metadata View As Heatmap View Comparison Customize Table

z-sc... -72.37 - -30.75 (1/24)

Analysis N...	Project	case.dis...	case.tiss...	case.subject...	case.tre...	compari...	comparisoncontrast	com...	web...	CP (...)	UR (...)	CN (...)	DE (...)	/	...
99- crohn's diseases	HumanDisease	crohn's disease (...)	sigmoid colon	ustekinumab	NA	Treatment vs. Co...	Tissue:ExperimentGroupSamplePathology...	GSE100833.GF	https://www...	-74.54	-74.83	-67.82	-72.28		-72.37
1- atopic dermatit	HumanDisease	atopic dermatitis	skin	NB-UVB phototherapy	NA	Treatment vs. Co...	SamplePathology:SamplingTime => Lesion...	GSE27887.GPL	http://www.n...	-70.71	-74.16	-66.33	-71.24		-70.61
1- rheumatoid artl	HumanDisease	rheumatoid arthr...	knee synovial tis...	methotrexate;plaque...	NA	Treatment vs. Co...	SamplingTime => post-treatment vs pre-tr...	GSE97165.GPL	https://www...	-78.17	-71.41	-60.00	-72.28		-70.47
1- ulcerative coliti	HumanDisease	ulcerative colitis ...	colonic mucosa	placebo	NA	Treatment vs. Co...	SubjectTreatment:SamplingTime:DiseaseSt...	GSE50594.GPL	https://www...	-52.70	-78.74	-67.82	-77.27		-69.13
11- psoriasis vulg	HumanDisease	psoriasis vulgaris	skin	PF06700841	NA	Treatment vs. Co...	SamplePathology:TreatmentGroup:Samplin...	GSE136757.GF	https://www...	-52.70	-80.00	-76.81	-64.65		-68.54
1- hepatitis B [live	HumanDisease	hepatitis B	liver	IFN alpha 2b	NA	Treatment vs. Co...	SamplingTime => post-treatment vs pre-tr...	GSE66698.GPL	https://www...	-66.67	-76.81	-64.03	-63.48		-67.75
2- rheumatoid artl	HumanDisease	rheumatoid arthr...	knee synovial tis...	tocilizumab	NA	Treatment vs. Co...	SubjectTreatment:SamplingTime => tociliz...	GSE45867.GPL	http://www.n...	-62.36	-80.00	-57.45	-65.79		-66.40
2- ulcerative coliti	HumanDisease	ulcerative colitis ...	colonic mucosa	vedolizumab	NA	Treatment vs. Co...	TreatmentStatus => vedolizumab vs none	GSE73661.GPL	https://www...	-47.14	-78.74	-65.57	-71.24		-65.67
14- atopic dermati	HumanDisease	atopic dermatitis	skin	placebo;triamcinolon...	NA	Treatment vs. Co...	TreatmentGroupSamplePathology:Samplin...	GSE140684.GF	https://www...	-47.14	-78.10	-61.64	-74.31		-65.30
1- alopecia areata	HumanDisease	alopecia areata	skin	tofacitinib	NA	Treatment vs. Co...	SamplingTime => week 8 vs pre-treatment	GSE80688.GPL	https://www...	-62.36	-68.56	-54.77	-69.11		-63.70
7- alopecia areata	HumanDisease	alopecia areata	skin	ruxolitinib	NA	Treatment vs. Co...	Response:SamplingTime => response -> ...	GSE80342.GPL	https://www...	-74.54	-71.41	-34.64	-71.24		-62.96
4- atopic dermatit	HumanDisease	atopic dermatitis	skin	cyclosporine A (CsA)	NA	Treatment vs. Co...	SamplePathology:SamplingTime => non-le...	GSE58558.GPL	https://www...	-57.74	-74.83	-56.57	-62.29		-62.86
1- atopic dermatit	HumanDisease	atopic dermatitis	skin	betamethasone;pime...	NA	Treatment vs. Co...	TreatmentStatus => betamethasone vs no...	GSE32473.GPL	https://www...	-52.70	-78.10	-51.96	-68.02		-62.70
9- bronchiolitis [ne	HumanDisease	bronchiolitis	nasal mucosa	glucocorticoid	NA	Treatment vs. Co...	DiseaseStage:AgeCategory:SubjectTreatm...	GSE113209.GF	https://www...	-47.14	-76.16	-73.48	-51.83		-62.15
21- psoriasis vulg	HumanDisease	psoriasis vulgaris	skin	PF06700841	NA	Treatment vs. Co...	ExperimentGroup:TreatmentGroup => Lesi...	GSE136757.GF	https://www...	-52.70	-76.16	-57.45	-61.08		-61.85
3- nonalcoholic ste	HumanDisease	nonalcoholic stea...	liver	bariatric surgery	NA	Treatment vs. Co...	DiseaseState:SubjectTreatment:SamplingT...	GSE83452.GPL	https://www...	-70.71	-64.03	-34.64	-69.11		-59.62
5- ulcerative coliti	HumanDisease	ulcerative colitis ...	colonic mucosa	vedolizumab	NA	Treatment vs. Co...	SubjectTreatment:SamplingTime => vedoli...	GSE73661.GPL	https://www...	-47.14	-71.41	-54.77	-64.65		-59.49
1- Friedreich ataxi	HumanDisease	Friedreich ataxia	peripheral blood	nicotinamide	NA	Treatment vs. Co...	Treatment => nicotinamide vs none	GSE42960.GPL	https://www...	-47.14	-70.71	-68.56	-50.37		-59.19
3- alopecia areata	HumanDisease	alopecia areata	skin	tofacitinib	NA	Treatment vs. Co...	SamplingTime => week 24 vs pre-treatme...	GSE111061.GF	https://www...	-57.74	-67.88	-46.90	-63.48		-59.00
17- normal control	HumanDisease	normal control	peripheral blood	isoniazid	NA	Treatment vs. Co...	Infection:Treatment => none -> isoniazid ...	GSE143731.GF	https://www...	-62.36	-72.80	-44.72	-55.99		-58.97
1- obesity [subcut:	HumanDisease	obesity	subcutaneous ad...	Roux-en-Y gastric by...	NA	Treatment vs. Co...	SamplingTime => post-treatment vs pre-tr...	GSE53376.GPL	http://www.n...	-66.67	-63.25	-37.42	-68.02		-58.84
19- psoriasis vulg	HumanDisease	psoriasis vulgaris	skin	PF06700841	NA	Treatment vs. Co...	ExperimentGroup:TreatmentGroup => Lesi...	GSE136757.GF	https://www...	-62.36	-70.71	-43.59	-57.30		-58.49
36- normal control	HumanDisease	normal control	peripheral blood	malaria vaccine;P. fal...	NA	Treatment vs. Co...	Gender:ExperimentGroup:SampleDescripti...	GSE102288.GF	https://www...	-47.14	-76.16	-47.96	-59.85		-57.78
1- normal control	HumanDisease	normal control	peripheral blood	HDAC inhibitor	NA	Treatment vs. Co...	ExperimentGroup => HDAC inhibitor 12 h...	GSE15735.GPL	https://www...	-62.36	-57.45	-44.72	-63.48		-57.00
15- normal control	HumanDisease	normal control	peripheral blood	DMSO	NA	Treatment vs. Co...	Infection:Treatment => none -> DMSO vs ...	GSE143731.GF	https://www...	-66.67	-69.28	-38.73	-53.25		-56.98
1- normal control	HumanDisease	normal control	peripheral blood	simvastatin	NA	Treatment vs. Co...	SamplingTime => hour 12 vs pre-treatment	GSE4883.GPL5	https://www...	-62.36	-64.03	-48.99	-51.83		-56.80
2- normal control	HumanDisease	normal control	endothelium	Transfection_mi...	NA	Treatment vs. Co...	Transfection => miR-27a-5p mimic vs cont...	GSE48006.GPL	http://www.n...	-23.57	-72.11	-66.33	-61.08		-55.77
11- hidradenitis su	HumanDisease	hidradenitis supp...	skin	adalimumab	NA	Treatment vs. Co...	SamplePathology:Response:SamplingTime ...	GSE155176.GF	https://www...	-57.74	-68.56	-37.42	-58.59		-55.57
5- psoriasis vulg	HumanDisease	psoriasis vulgaris	epidermis	NB-UVB phototherapy	NA	Treatment vs. Co...	SamplingTime => post-treatment vs pre-tr...	GSE53431.GPL	https://www.n...	-47.14	-67.82	-50.00	-55.99		-55.24
98- crohn's diseases	HumanDisease	crohn's disease (...)	sigmoid colon	ustekinumab	NA	Treatment vs. Co...	Tissue:ExperimentGroupSamplePathology...	GSE100833.GF	https://www...	-74.54	-74.83	-67.82	-72.28		-72.37
16- normal control	HumanDisease	normal control	peripheral blood	ethambutol	NA	Treatment vs. Co...	Infection:Treatment => none -> ethambut...	GSE143731.GF	https://www...	-47.14	-71.41	-46.90	-50.37		-53.96
							adipose tiss...	GSE42902.GPL	http://www.n...	-47.14	-66.33	-53.85	-47.32		-53.66
							17A/F heter...	GSE150805.GF	https://www...	-57.74	-60.83	-36.06	-59.85		-53.62
							roup => Lesi...	GSE133385.GF	https://www...	-62.36	-42.43	-47.96	-61.08		-53.46
							> amikacin ...	GSE143731.GF	https://www...	-57.74	-70.71	-33.17	-51.83		-53.36
1- atopic dermatit	HumanDisease	atopic dermatitis	skin	cyclosporine A (CsA)	NA	Treatment vs. Co...	SamplePathology:SamplingTime => Lesion...	GSE58558.GPL	https://www...	-57.74	-80.00	-68.56	-64.65		-53.30
1- normal control	HumanDisease	normal control	peripheral blood	suberoylanilide h...	NA	Treatment vs. Co...	Treatment => suberoylanilide hydroxamic...	GSE102187.GF	https://www...	-66.67	-50.14	-28.28	-68.02		-53.28
2- atopic dermatit	HumanDisease	atopic dermatitis	skin	cyclosporine A (CsA)	NA	Treatment vs. Co...	SamplePathology:SamplingTime => Lesion...	GSE58558.GPL	https://www...	-57.74	-83.07	-67.08	-62.29		-53.11

Selected 0 / 4784

Some of these treatments might be effective for atopic dermatitis

Agenda

Perform pathway analysis on your own 'omics data

Compare and contextualize your results with other studies

Build networks from scratch and explore relationships

Options to tackle differential expression before using IPA



Build networks from scratch and explore relationships

Build custom pathways using our biomedical knowledge

- Search for the shortest paths between genes, drugs, and diseases
- Identify pathways, regulators, and diseases influenced by your network

Simulate changes in activity and predict downstream effects

- Molecule Activity Predictor: simulate changes in activity in silico
- Pattern Search: use your custom network as a directional gene signature

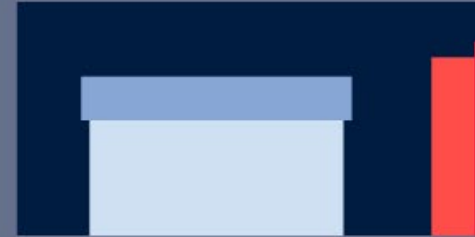
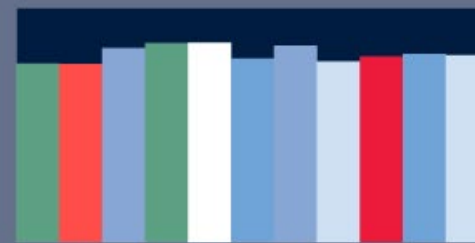

What kinds of questions can you answer without your own data?

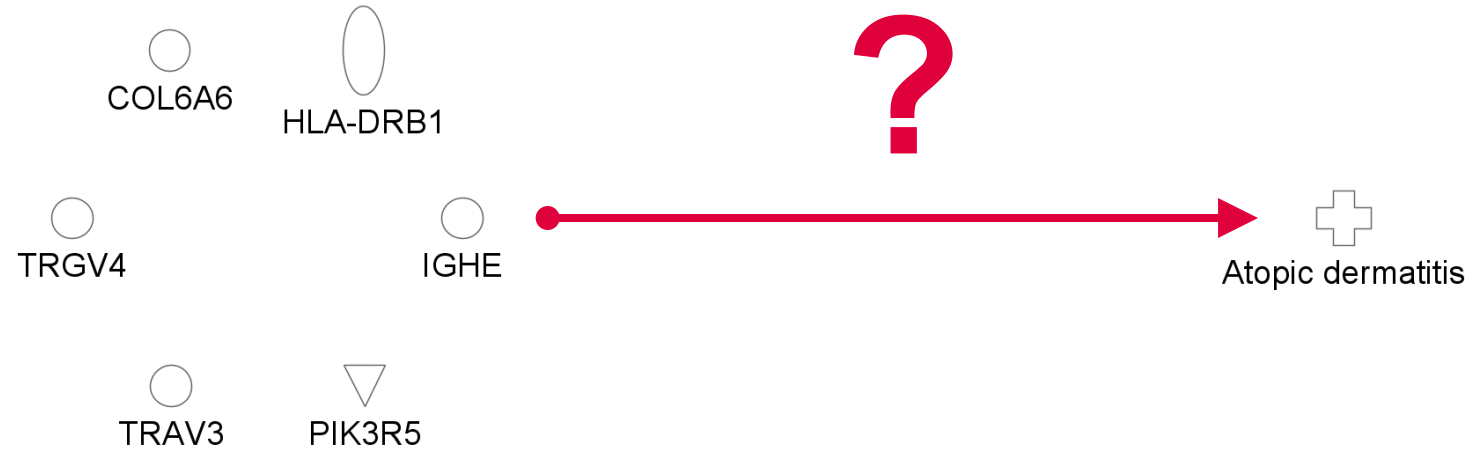

Build networks from scratch and discover potential drug targets

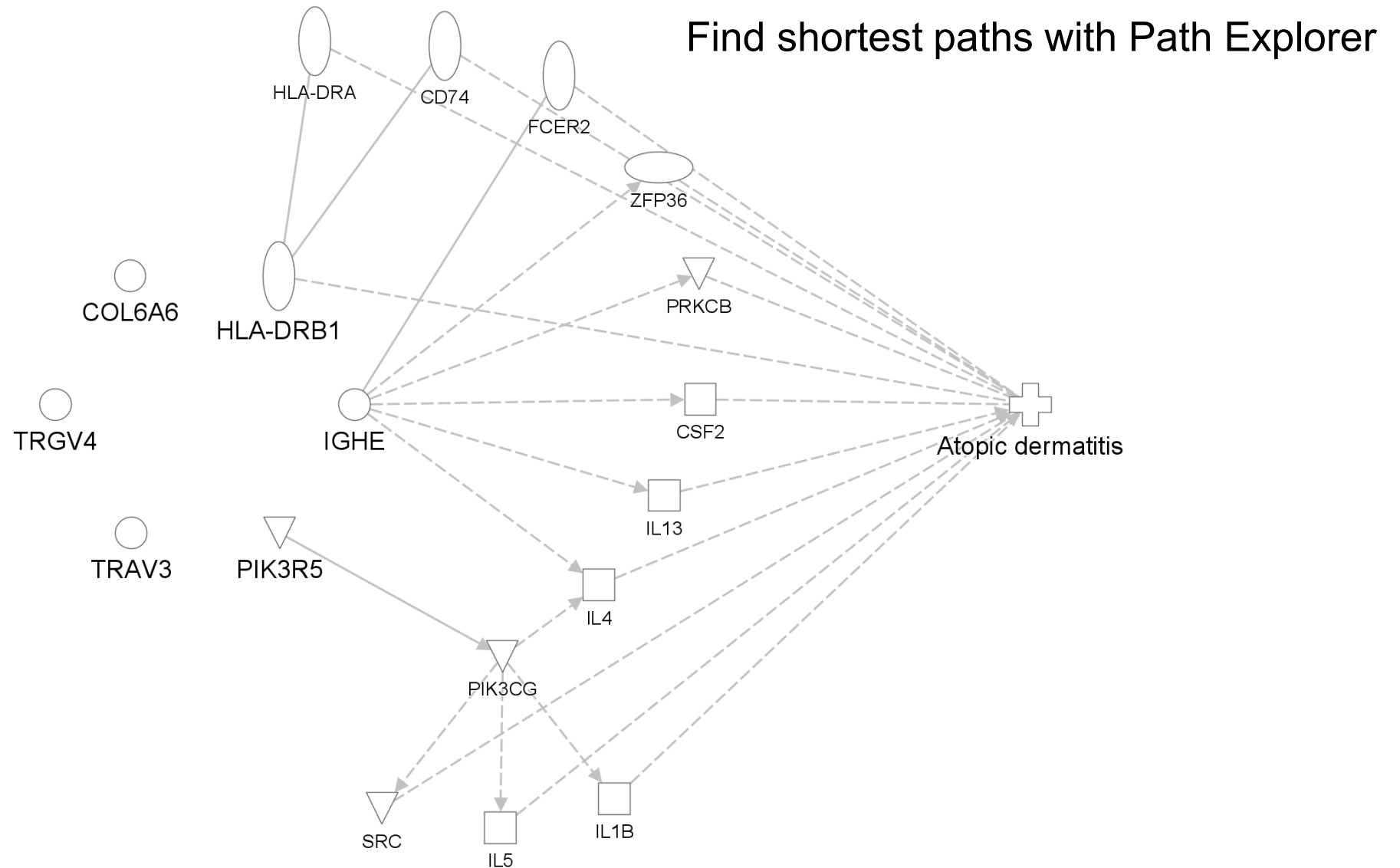

Build networks from scratch and discover potential drug targets

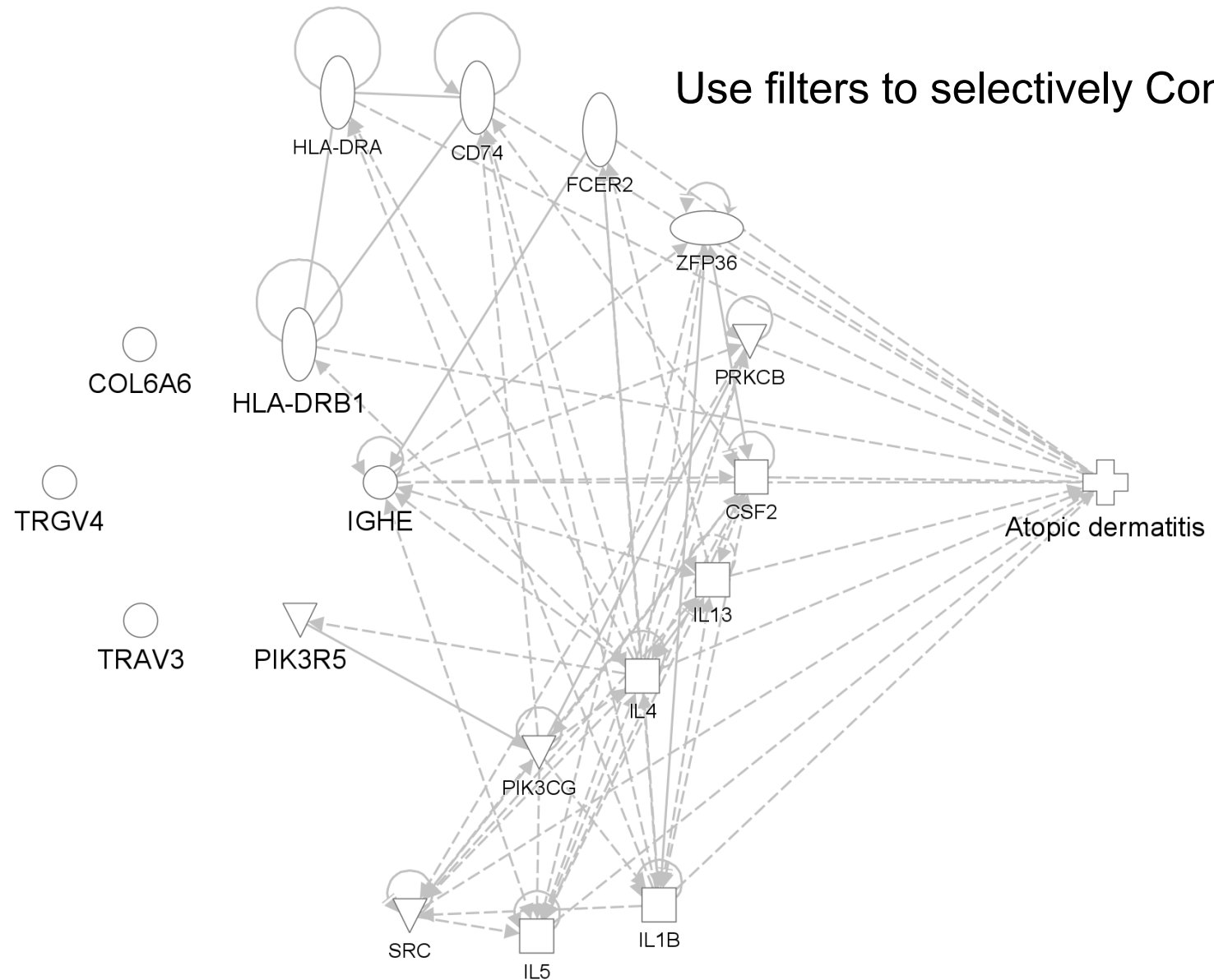

Build networks from scratch and discover potential drug targets

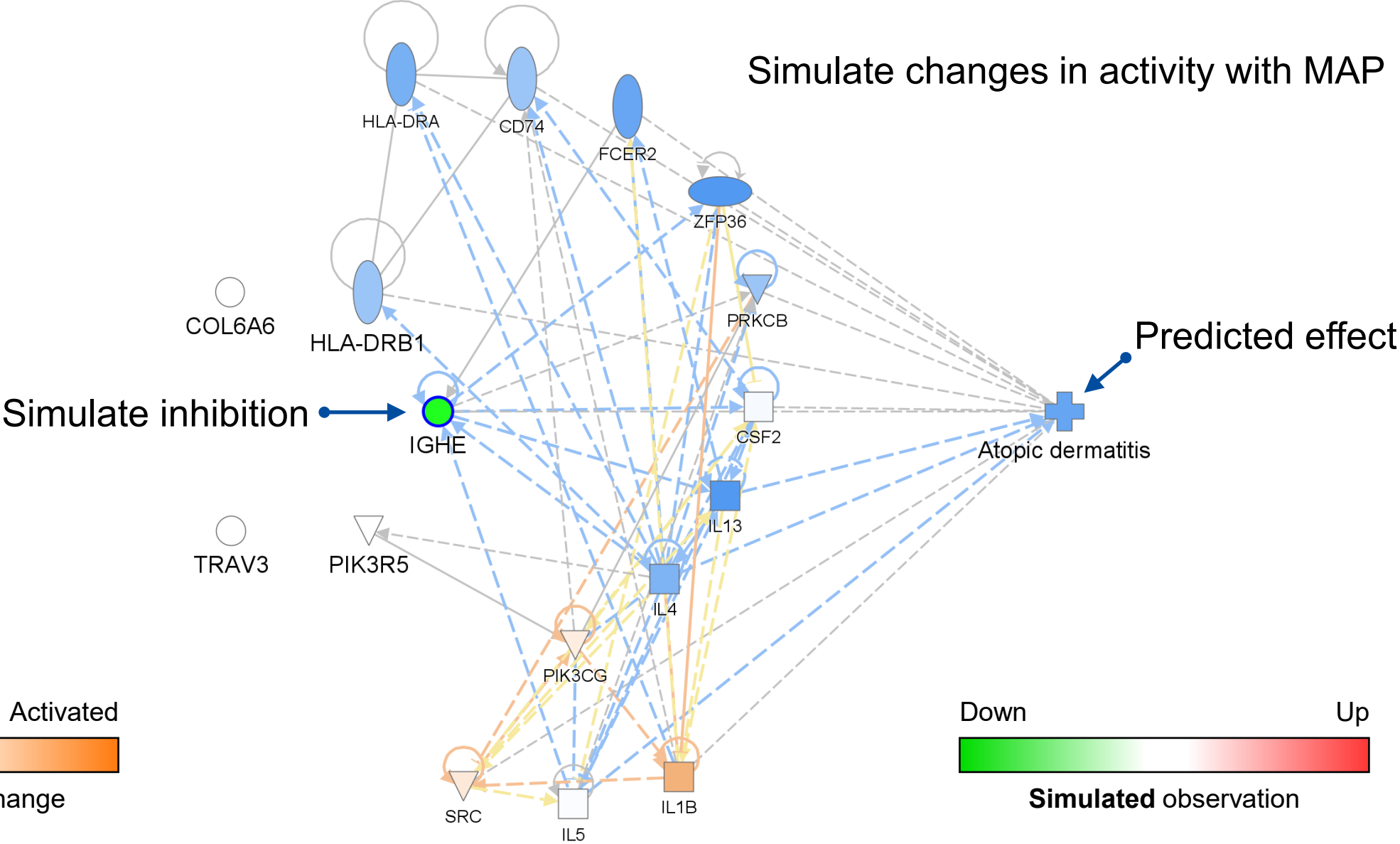

Build networks from scratch and discover potential drug targets

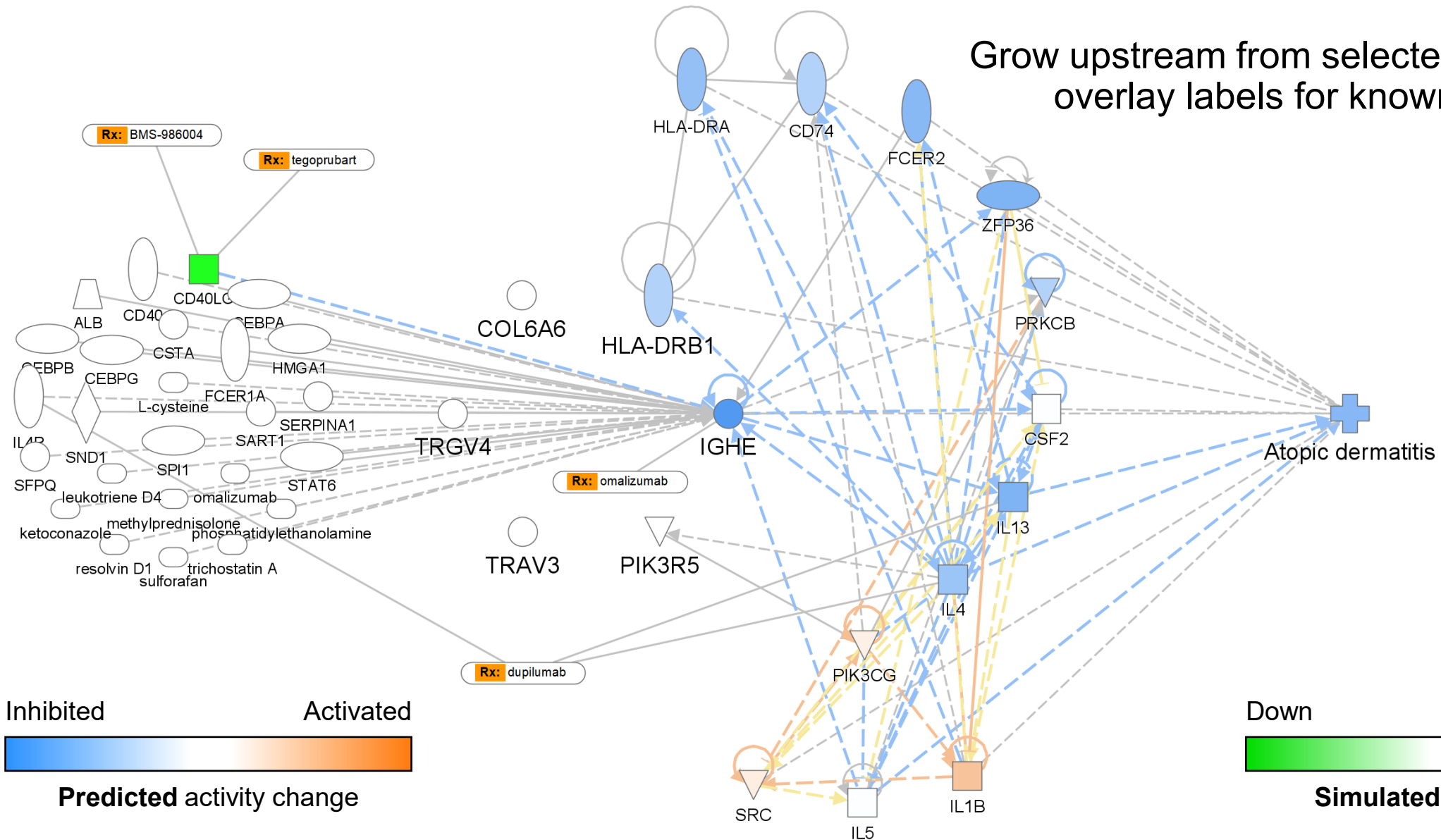

BMS-986004 could be a potential candidate for atopic dermatitis

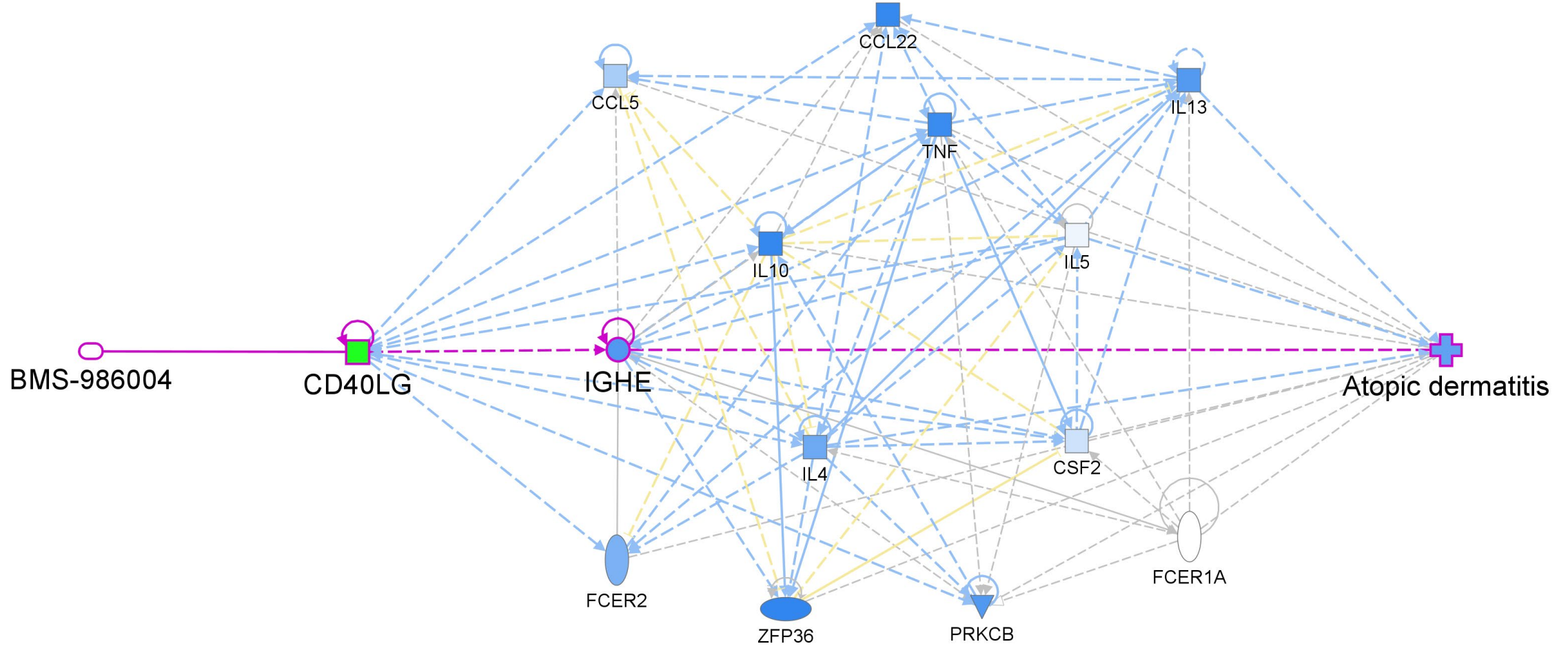

Indication	FDA Approval Status	Trial Status	Clinical Trial Sponsor(s)	NCT#	Last Updated
immune thrombocytopenic purpura	Phase 1/Phase 2	Completed	Bristol-Myers Squibb	NCT02273960	2019-07-15
acute graft-vs-host disease	Phase 1	Recruiting	H. Lee Moffitt Cancer Center and Research Institute	NCT03605927	2022-12-30
acute graft-vs-host disease	Phase 1	Recruiting	H. Lee Moffitt Cancer Center and Research Institute	NCT03605927	2022-12-30

IPA

File Edit View Window Help

Genes and Chemicals Diseases and Functions Pathways and Lists Datasets and Analyses

Create New... nos2 Search Advanced Search

Provide Feedback | Support Kyle Nilson Close IPA

Process RNA-seq data QIAGEN Land Explorer

Search Results

Genes and Chemicals

Add To My Pathway New My Pathway Matched Dataset BioProfiler Interaction Network Activity Plot

Saved My Pathway

The search for nos2 match

<input type="checkbox"/>	#	Symbol	Matche	Synonym(s)	Entrez Gene Name	Location	Type(s)	Biomarker Application(s)
<input type="checkbox"/>	1	NANOS2	NOS2	nanos C2HC-type zinc finger 2, NOS2, RGD1562436, ZC2HC12B	nanos C2HC-type zinc finger 2	Cytoplasm	other	
<input checked="" type="checkbox"/>	2	NOS2	NOS2, NOS2A, Nos2	CALCIUM-INDEPENDENT NOS, Hepatocyte NOS, HEP-NOS, Inducible NOS, INOS, LOC497963, MAC-NOS, nitric oxide synthase 2, nitric oxide synthase 2, inducible, NOS, NOS2A, NOS-II	nitric oxide synthase 2	Cytoplasm	enzyme	diagnosis
<input type="checkbox"/>			nos2	AIF3BL3, CMCU, NF-kappa B, NF-kappa B (p65), NF KAPPA B subunit P65, NFkB, NFKB3, NF-k B (p65), NFkB/p65, NF-k B, NF-k B (p65), NF-kB p65, NF κ B subunit P65, nos2, p65, p65 NF-kappa B, p65 NFKB, p65 NF-k B, p65/Rela, RELA proto-oncogene, NF-kB subunit, v-rel reticuloendotheliosis viral oncogene homolog A (avian	RELA proto-oncogene, NF-kB subunit	Nucleus	transcription regulator	diagnosis, efficacy
<input type="checkbox"/>	4	NOS2P1	NOS2C	nitric oxide synthase 2 pseudogene 1, NOS2C, RP11 19P225	nitric oxide synthase 2 pseudogene 1	Other	other	
<input type="checkbox"/>	5	NOS2P2	NOS2B	nitric oxide synthase 2 pseudogene 2, NOS2B	nitric oxide synthase 2 pseudogene 2	Other	other	
<input type="checkbox"/>	6	Nos2-ps1	Nos2-ps1	LOC108352181, nitric oxide synthase 2, pseudogene 1	nitric oxide synthase 2, pseudogene 1	Other	other	
<input type="checkbox"/>	7	PPE2:NOS2 gene	PPE2:NOS2 gene			Cytoplasm	complex	

Selected/Total rows : 1/7

Search for genes of interest using Genes and Chemicals search

IPA

File Edit View Window Help

Genes and Chemicals **Diseases and Functions** Pathways and Lists Datasets and Analyses

Create New... ulcerative colitis Search Advanced Search

Search Results

Genes and Chemicals **Diseases and Functions**

Add To My Pathway New My Pathway Annotations Show Findings Effect on Function BioProfiler Activity Plot Show Functions Expand Functions

The search for ulcerative colitis returned 100 results. Saved My Pathway New My Pathway 3

Matching Diseases & Functions

Matching Diseases & Functions	Associated Molecule
<input type="checkbox"/> Organismal Injury and Abnormalities	794
<input type="checkbox"/> ulcerative colitis	794
<input checked="" type="checkbox"/> Ulcerative colitis	793
<input type="checkbox"/> Active ulcerative colitis [life-threatening ulcerative colitis,very severe ulcerative colitis,...]	39
<input type="checkbox"/> Active ulcerative colitis [adequate ulcerative colitis,modest ulcerative colitis]	39
<input type="checkbox"/> Moderately to severely active disease stage ulcerative colitis [moderately to severely active ulcerative colitis]	35
<input type="checkbox"/> Refractory ulcerative colitis	
<input type="checkbox"/> Mild to moderate stage ulcerative colitis	
<input type="checkbox"/> Mildly to moderately active disease stage ulcerative colitis [mild to moderately active ulcerative colitis,mild to moderately active disease stage ulcerative colitis]	7
<input type="checkbox"/> Mild ulcerative colitis [mild grade ulcerative colitis,very mild disease stage ulcerative colitis,...]	6
<input type="checkbox"/> Stable disease stage ulcerative colitis [stable ulcerative colitis]	3
<input type="checkbox"/> Recurrent ulcerative colitis [cyclical ulcerative colitis,recurring ulcerative colitis]	1
<input type="checkbox"/> Advanced stage ulcerative colitis [late stage ulcerative colitis,severe disease stage ulcerative colitis,...]	1
<input type="checkbox"/> Grade 3-6 ulcerative colitis [grade III-VI ulcerative colitis]	1
<input type="checkbox"/> ulcerative or indeterminate colitis	793
<input type="checkbox"/> Ulcerative or indeterminate colitis [ulcerative colitis,indeterminate colitis]	793
<input type="checkbox"/> active ulcerative colitis	66
<input type="checkbox"/> Active ulcerative colitis	66
<input type="checkbox"/> Mild to moderate stage active ulcerative colitis [mild to moderate active ulcerative colitis,mild-moderate stage active ulcerative colitis]	11
<input type="checkbox"/> Mildly to moderately active disease stage active ulcerative colitis [mild to moderately active disease stage active ulcerative colitis,mild to moderately active active ulcerative colitis]	7
<input type="checkbox"/> severe active ulcerative colitis	35
<input type="checkbox"/> Severe active ulcerative colitis [active severe ulcerative colitis]	35
<input type="checkbox"/> Refractory severe active ulcerative colitis [resistant active severe ulcerative colitis,intractable active severe ulcerative colitis,...]	14
<input type="checkbox"/> moderate active ulcerative colitis	34
<input type="checkbox"/> Moderate active ulcerative colitis [active moderate ulcerative colitis]	34

1

2

3

4

Search for diseases, symptoms, or phenotypes using Diseases and Functions search

Add nodes only for the selected diseases or functions

Select source

Add

Diseases or Functions

Molecules

Both

OK Cancel

4

Build > Path Explorer is for finding the shortest paths between nodes

My Pathways
New My Pathway 3
Build Overlay Path Designer Pattern Search View: Zoom: Export:

Tool: Path Explorer
1 shortest path was found.
Filter Summary
Consider all molecules and/or interactions

General Settings
Interactions
 Direct Indirect
Set A Add Remove
NOS2
Direction: From Set A to Set B
Set B Add Remove
Ulcerative colitis
 Use Ingenuity Knowledge Base
 Use Molecules from Analysis/Dataset/List...
Current Analysis/Dataset/List: None selected
Change Analysis/Dataset/List

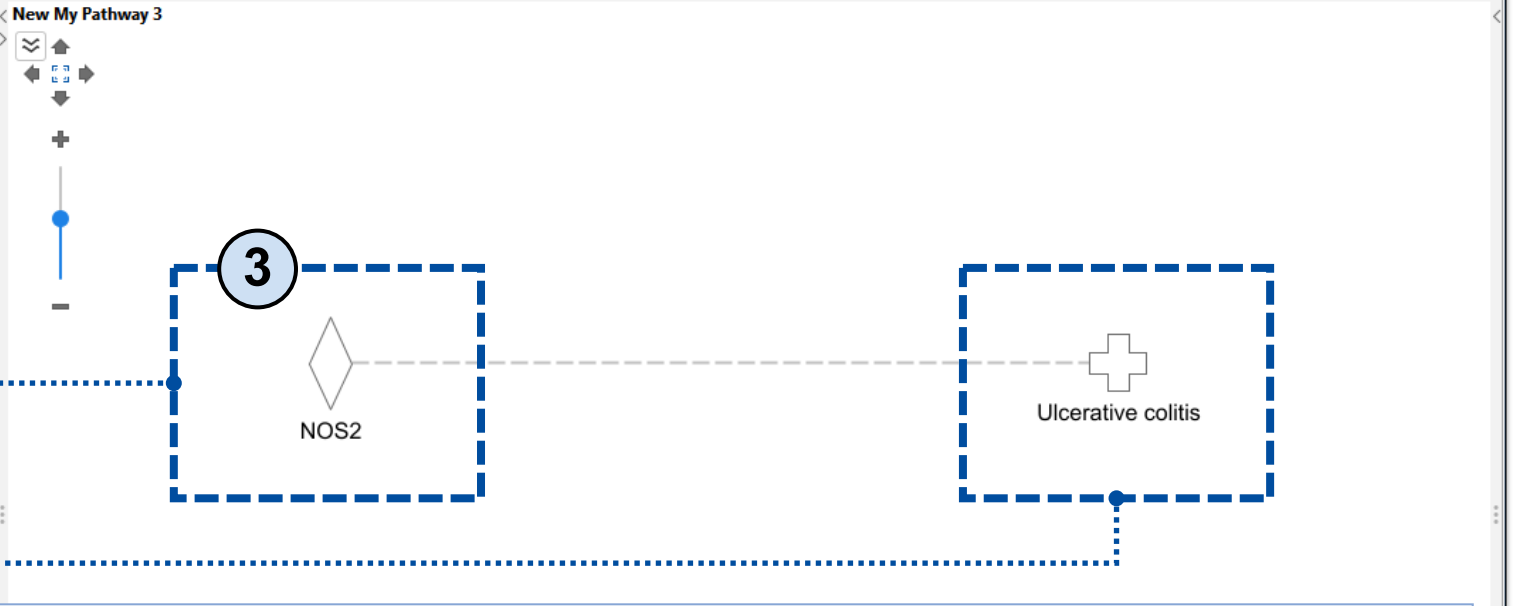

Choose Set A, Set B, and the relationship direction to consider

- > Data Sources All
- > miRNA Confidence Level All
- > Species All
- > Tissues & Cell Lines All

Save As Preferences Restore From Prefs Reset Apply

© 2000-2025 QIAGEN. All rights reserved.

Add To My Pathway Highlight View Shortest Paths (1) Paths 1 - 1

Paths	Set A Molecules	Set B Molecules
<input checked="" type="checkbox"/>	NOS2	Ulcerative colitis

4

My Pathways

New My Pathway 3

Build Overlay Path Designer Pattern Search View: Zoom: Export:

Tool: Path Explorer

40 shortest paths were found.

Filter Summary Consider all molecules and/or relationships

General Settings

Interactions

Direct Indirect

Set A Add Remove

NOS2

Direction: From Set A to Set B

Set B Add Remove

Ulcerative colitis

Use Ingenuity Knowledge Base
 Use Molecules from Analysis/Dataset/List...
 Current Analysis/Dataset/List: None selected
 Change Analysis/Dataset/List

> Data Sources All
 > miRNA Confidence Level All
 > Species All
 > Tissues & Cell Lines All

Save As Preferences Restore From Prefs Reset Apply

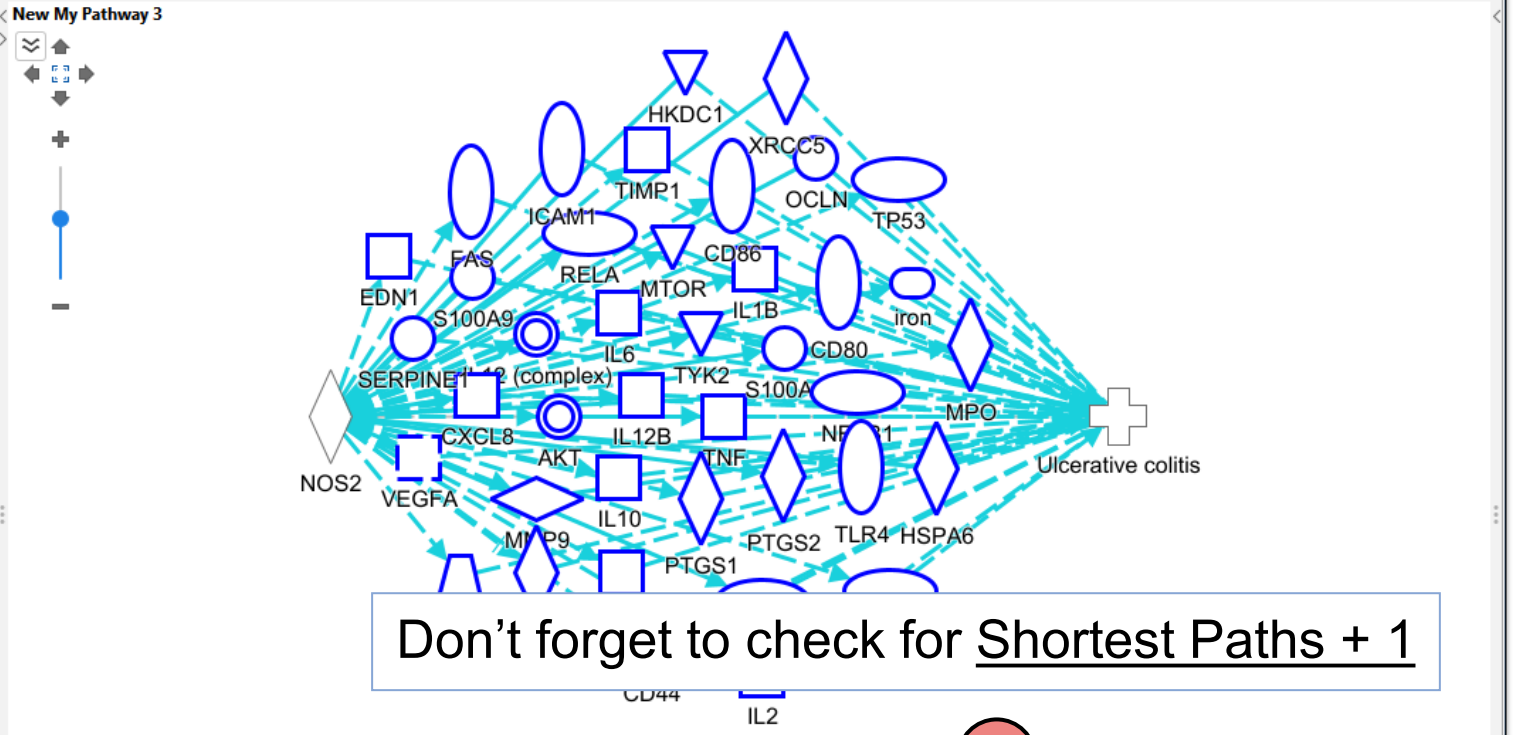

Don't forget to check for Shortest Paths + 1

© 2000-2025 QIAGEN. All rights reserved.

Add To My Pathway Highlight

5

Shortest Paths + 1 (40) Path 1 - 40

Paths	Set A Molecules	Node 1	Set B Molecules
1	NOS2	TNF	Ulcerative colitis
2	NOS2	PTGS2	Ulcerative colitis
3	NOS2	PTGS1	Ulcerative colitis
4	NOS2	IL12B	Ulcerative colitis
5	NOS2	TYK2	Ulcerative colitis

6

Build > Connect shows how selected nodes interact with each other

My Pathways

New My Pathway 3

Tool: Connect

Connect selected molecules based on criteria. Click Apply to view new connections.

Filter Summary

Consider only molecules where diseases = Gastrointestinal Disease

General Settings

Interactions

Direct Indirect

Data Sources All

miRNA Confidence Level All

Species All

Tissues & Cell Lines All

Mutation All

Relationship Types All

Publication Date Range All

Node Types All

Diseases Gastrointestinal Disease

- Connective Tissue Disorders
- Dental Disease
- Dermatological Diseases and Conditions
- Developmental Disorder
- Endocrine System Disorders
- Gastrointestinal Disease
- Hematological Disease

Save As Preferences Restore From Prefs Reset Apply

3

1

2

4

Ulcerative colitis

IPA

File Edit View Window Help

Genes and Chemicals Diseases and Functions Pathways and Lists Datasets and Analyses

Create New... Search Advanced Search

Provide Feedback | Support Kyle Nilson Close IPA

Process RNA-seq data QIAGEN Land Explorer

QIAGEN

My Pathways

New My Pathway 3

Build Overlay Path Designer Pattern Search View: Zoom: Export:

Overlay: MAP (Molecule Activity Predictor)

Clear

You can predict the upstream and downstream effects of a molecule or on inhibition on other molecules. Begin by overlaying measurement values from a dataset or analysis, and then interactively specifying activation in silico below.

Predict effect of dataset or in silico changes

Prediction On Display prediction legend

Predict effects:

Upstream and Downstream

Activate or inhibit molecules interactively in silico

Select the value to apply and then click the molecules you wish to apply them to.

Use measurement values from a dataset or Analysis

Current Analysis/Dataset: none selected

Change Analysis/Dataset List

1

2

3

4

Down Up

Simulated observation

NOS2

Ulcerative colitis

Inhibited Activated

Predicted activity change

Overlay > Molecule Activity Predictor simulates changes in activity

Pattern Search: search for your directional network in the literature

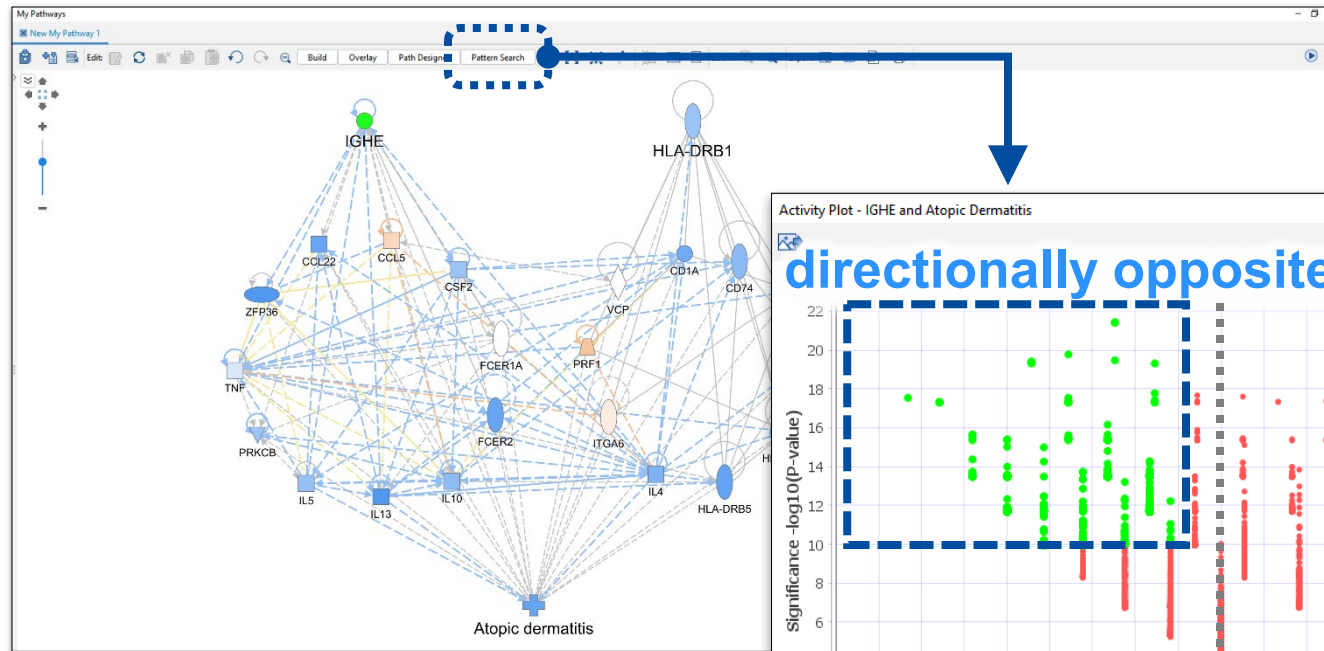

Studies are arranged by enrichment (p-value) and directionality (z-score) of queried genes

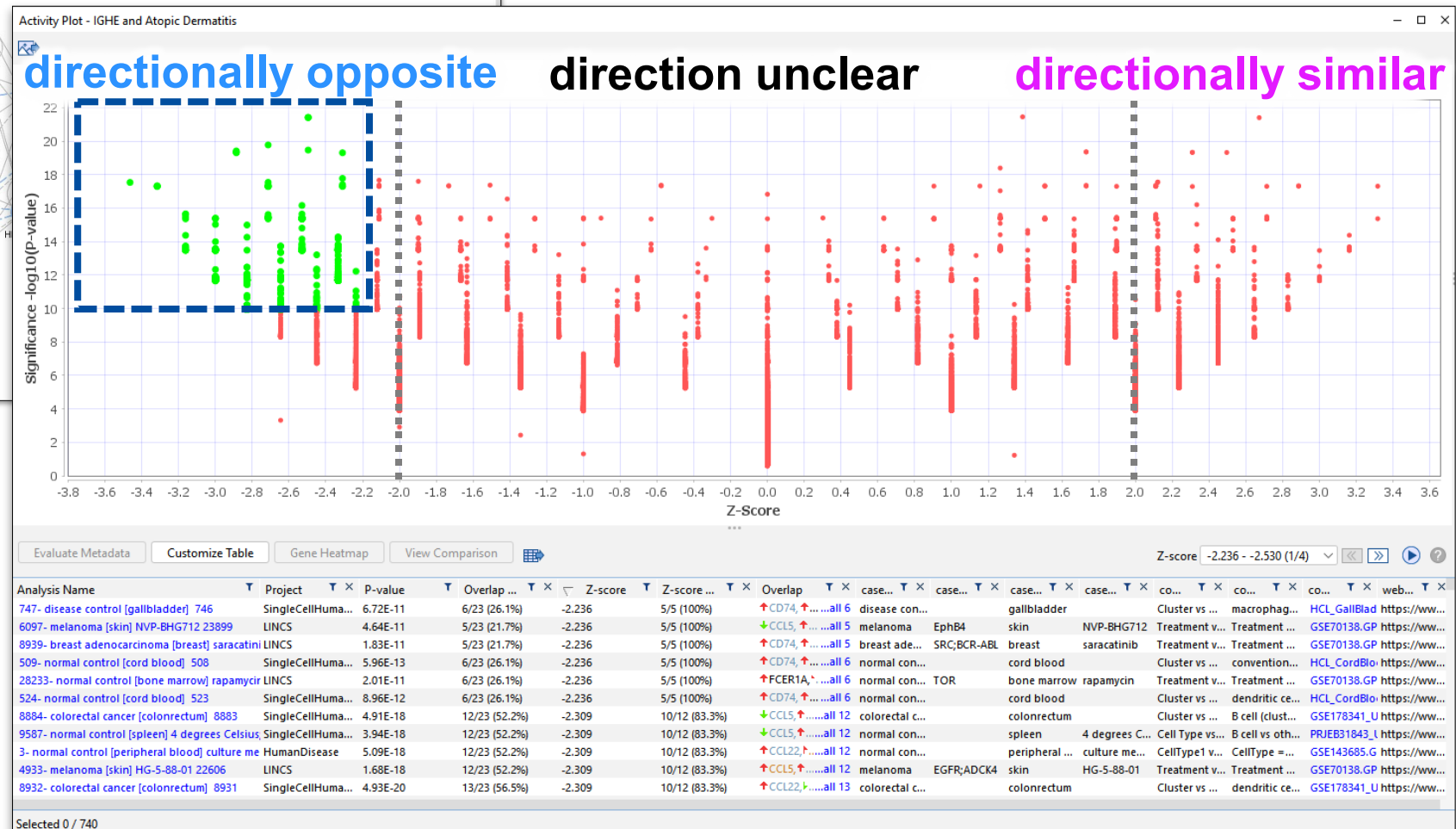

Compare your signature vs. 260,000+ curated studies and your previous IPA results

Pattern Search queries pre-computed studies using enrichment and directionality

My Pathways

New My Pathway 3

Build Overlay Path Designer Pattern Search View: Zoom: Export:

Activity Plot - New My Pathway 3

176356 Analyses for New My Pathway 3

directionally opposite directionally similar

2

3

Find compounds with similar effects

Analysis Name	P-value	Z-score	Overlap	case.diseasestate	case.subjecttreat...	comparisoncateg...	comparisoncontrast
98- crohn's disease (CD) [sig]	1.12E-21	4.000	↓CCL2, ↓CD44, ↓... all 16	crohn's disease (CD)	ustekinumab	Treatment vs. Control	Issue:ExperimentGroup:SamplePathology:SamplingTime => sigmoi.
1- ulcerative colitis (UC) [col]	8.41E-22	4.000	↓CD44, ↓CD80, ↓... all 16	ulcerative colitis (UC)	placebo	Treatment vs. Control	ment:SamplingTime:DiseaseStage => placebo:active dis.
1- obesity;type 2 diabetes m...	1.42E-18	3.742	↓CCL2, ↓CD44, ↓... all 14	obesity;type 2 diabetes m...		Treatment vs. Control	=> FGF19 vs GFP
1- sarcoidosis [skin] NA CMF	8.30E-15	3.464	↓CD80, ↓CD86, ↓... all 12	sarcoidosis	tofacitinib	Treatment vs. Control	... samplingTime => complete response -> post-treatment vs
34- crohn's disease (CD) [ile]	1.80E-16	3.464	↓CD44, ↓CD80, ↓... all 13	crohn's disease (CD)	none		
11- crohn's disease (CD) [col]	1.44E-16	3.464	↓CCL2, ↓CXCL8, ↓... all 13	crohn's disease (CD)	auto		
1- chronic obstructive pulm...	4.34E-15	3.464	↓CCL2, ↓CXCL8, ↓... all 12	chronic obstructive pulmo...			
2- ulcerative colitis (UC) [col]	4.86E-15	3.464	↓CXCL8, ↓ICAM1, ↓... all 12	ulcerative colitis (UC)	vedo		
1- atopic dermatitis [skin] N...	1.79E-15	3.464	↓CCL2, ↓CD80, ↓... all 12	atopic dermatitis	berdazimer sodium	Treatment vs. Control	ExperimentGroup => lesional, berdazimer sodium, 2% twice/day, we.

Pattern Search queries pre-computed studies using enrichment and directionality

Activity Plot - New My Pathway 3

176356 Analyses for New My Pathway 3

directionally opposite

directionally similar

Analysis Name	P-value	Z-score	Overlap	case.diseasestate	comparisoncateg...	comparisoncontrast
1- pancreatic ductal adenocarcinoma	8.95E-04	-2.000	↑CD86, ↑CXCL8, ↑L...all 4	pancreatic ductal adenocarcinoma	Disease vs. Normal	PairingStatus:OncoSampleType => paired -> Primary Tumor vs Solid Tissue Normal
1- lipid metabolism disorder	5.65E-04	-2.000	↑CD44, ↑CD86, ↑IL...all 4	lipid metabolism disorder	Disease vs. Normal	=> lipid metabolism disorder vs normal control
13- Huntington's disease (H)	4.22E-04	-2.000	↑CD44, ↑FAS, ↑S10...all 4	Huntington's disease (HD)	Disease vs. Normal	age => frontal cortex -> IV vs normal
8- myelodysplastic syndrome	8.36E-04	-2.000	↑CCL2, ↑CD80, ↑IL1B...all 4	myelodysplastic syndrome	Disease vs. Normal	Comparison: DiseaseState => enythroid precursor cell -> myelodysplastic syndrome
4- systemic lupus erythematosus (SLE)	7.39E-04	-2.000	↑LCN2, ↑SERPINE1, ↑...all 4	systemic lupus erythematosus (SLE)		
1- colorectal cancer	6.69E-05	-2.000	↑CD44, ↑CXCL8, ↑...all 5	colorectal cancer		
1- pancreatic cancer	8.62E-04	-2.000	↑CXCL8, ↑LCN2, ↑...all 4	pancreatic cancer		
13- atherosclerosis [spleen]	7.25E-04	-2.000	↑CD86, ↑IL1B, ↑IL6, ↑...all 4	atherosclerosis		
1- rheumatoid arthritis (RA)	8.88E-04	-2.000	↑ICAM1, ↑MMP9, ↑...all 4	rheumatoid arthritis (RA)	Disease vs. Normal	ExperimentGroup => DMARD-IR rheumatoid arthritis vs normal control

3

Search for drug repurposing targets

Agenda

Perform pathway analysis on your own 'omics data

Compare and contextualize your results with other studies

Build networks from scratch and explore relationships

Options to tackle differential expression before using IPA





Options to tackle differential expression before using IPA

GEO2R

- Quick option for published datasets

QIAGEN RNA-Seq Analysis Portal

- Easy to use FASTQ-to-IPA pipeline

QIAGEN CLC Genomics Workbench

- Our comprehensive analysis suite for short and long sequencing reads

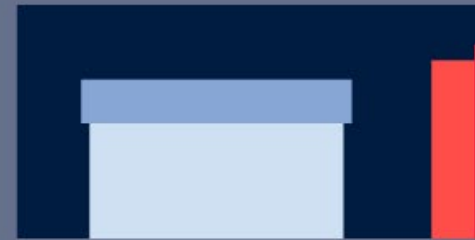
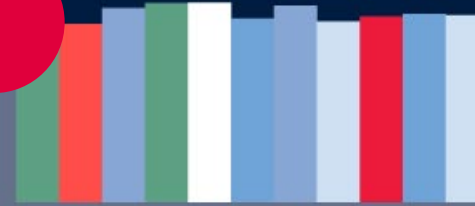

Ingenuity Pathway Analysis uses case vs. control DEGs as input

This can be a simple list with arbitrary values

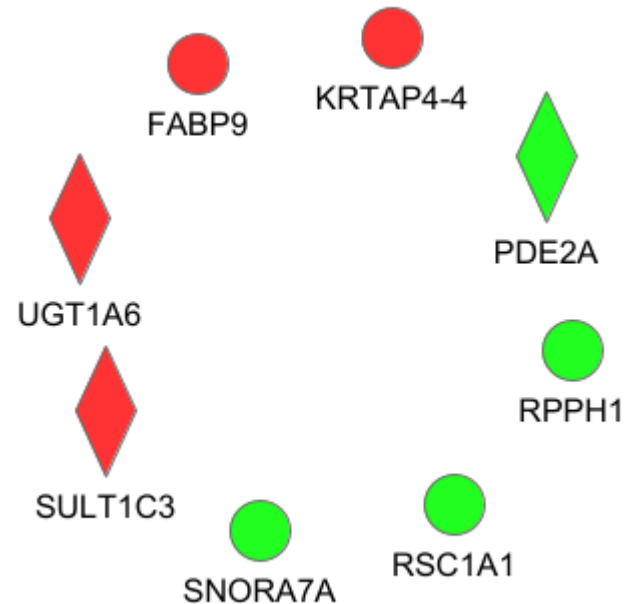

Gene	Change
FABP9	2
KRTAP4-4	2
SULT1C3	2
UGT1A6	2
PDE2A	-2
RPPH1	-2
RSC1A1	-2
SNORA7A	-2

Ingenuity Pathway Analysis uses case vs. control DEGs as input



This can be a differential expression table with ratios, fold changes, or log2FCs

IDs (required)

Ratio, fold change, etc.

Significance (optional)

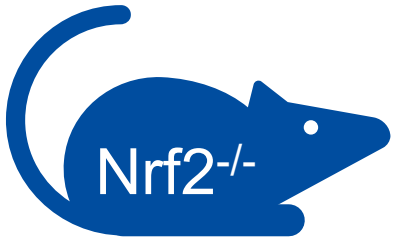

Knockout vs. wild type

	Transcript IDs	Ratio KO vs WT	p-value KO vs WT	Adj p-value KO vs WT
1				
2	NM_008866	1.02453	0.805551	0.971466808
3	NM_001159751	0.952735	0.184285	0.736421598
4	NM_133826	0.95185	0.279682	0.798486361
5	NM_001204371	0.92321	0.215736	0.758991902
6	ENSMUST00000027040	1.01667	0.795501	0.96971034
7	NM_001195732	1.00906	0.910633	0.987645184
8	NR_045188	0.990928	0.869495	0.981378292
9	NM_183028	0.921393	0.256484	0.784821849
10	NM_021511	0.932214	0.34333	0.831316277
11	ENSMUST00000144177	0.954012	0.45081	0.875692461
12	BC066997	1.04638	0.469901	0.882652167
13	NR_040462	0.881149	0.0974207	0.644692854
14	NM_133220	1.12049	0.0580533	0.57002282
15	NM_177722	1.02386	0.624477	0.932387654
16	NM_026493	0.990948	0.857147	0.97936759
17	NM_029525	0.873437	0.0734839	0.602439682
18	NM_001160369	1.01077	0.862964	0.980443879
19	NR_045297	0.980747	0.734801	0.957595072
20	NM_001198565	1.07234	0.412319	0.8723899



Core analysis results

Summary

Perform pathway analysis on your own 'omics data

Compare and contextualize your results with other studies

Build networks from scratch and explore relationships

Options to tackle differential expression before using IPA





ts-bioinformatics@qiagen.com

Technical and Scientific Support

kyle.nilson@qiagen.com

Field Software Trainer

brittany.kilb@qiagen.com

Senior Account Manager